

Chapter 10: Recreation Trail Management

- [10.1 Introduction](#)
- [10.2 Trail Planning](#)
 - [10.2.1 Concept Planning](#)
 - [10.2.2 Trail Establishment](#)
 - [10.2.3 Trail Assessment](#)
- [10.3 Trail Design](#)
 - [10.3.1 Principles of Trail design](#)
 - [10.3.2 User Requirements](#)
 - [10.3.3 Environmental Considerations](#)
 - [10.3.4 Design Considerations](#)
 - [10.3.5 Guidelines for Specific Trail Classes](#)
 - [10.3.6 Final Design Plan](#)
- [10.4 Trail Construction](#)
 - [10.4.1 Preparation for Trail Construction](#)
 - [10.4.2 Trail Construction Procedures](#)
 - [10.4.3 Trail Drainage](#)
 - [10.4.4 Trail Bridging](#)
 - [10.4.5 Trail Steps and Ladders](#)
- [10.5 Trail Monitoring and Maintenance](#)
 - [10.5.1 Trail Condition Log](#)
 - [10.5.2 Maintenance Levels](#)
 - [10.5.3 Trail Monitoring](#)
 - [10.5.4 Summer Use Trail Maintenance](#)
 - [10.5.5 Cross country Ski Trail Maintenance](#)
 - [10.5.6 Trail Rehabilitation](#)
 - [10.5.7 Cooperative Projects](#)
- [10.6 References](#)

List of Figures

- [1 Trail design process](#)
- [2 Slope gradients](#)
- [3 Drainage across a trail \(low runoff\)](#)
- [4 Drainage intercepted \(high runoff\)](#)
- [5 Placement of waterbars](#)
- [6 Log waterbar](#)
- [7 Poor trail design](#)
- [8 Good trail design](#)
- [9 Taking advantage of topography](#)
- [10 Handrails on special needs trails](#)
- [11 Clearing the trail](#)
- [12 Removal of large branches](#)
- [13 Windfall clearing](#)
- [14 Trailbed construction on different slideslope grades](#)
- [15 Trailbed construction on a sideslope](#)
- [16 Trailbed construction in talus and rubble](#)
- [17 Switchback details](#)
- [18 Log retaining wall](#)
- [19 Timber retaining wall](#)
- [20 Dry stone retaining wall](#)
- [21 Trail crown](#)
- [22 Typical drainage depression](#)
- [23 Drainage dip](#)
- [24 Log water bar](#)

- [25 Rock water bar construction](#)
- [26 Typical culvert with ditch](#)
- [27 Rock culvert](#)
- [28 Open rock culvert](#)
- [29 Turnpike](#)
- [30 Switchback drainage details](#)
- [31 Log rounds](#)
- [32 Stepping stones](#)
- [33 Corduroy showing spacing for drainage channels](#)
- [34 Flexible plank decking](#)
- [35 A curved boardwalk reduces visual impact](#)
- [36 Cross-section, elevation and view of log-decking on stringers](#)
- [37 Single plank decking in sills](#)
- [38 Post supported boardwalk](#)
- [39 Post and sill boardwalk with handrail](#)
- [40 Standard Duckboard](#)
- [41 Duckboard with stringer](#)
- [42 Notching log stringers](#)
- [43 Single log bridge with handrail](#)
- [44 Simple two-log bridge](#)
- [45 Three stringer bridge](#)
- [46 Log bridge with timber decking](#)
- [47 Bridge with decking and handrails](#)
- [48 Rise to run diagram](#)
- [49 Boulder steps](#)
- [50 Log steps](#)
- [51 Curved timber steps](#)
- [52 Ramped steps](#)
- [53 Plank steps](#)
- [54 Crib ladder](#)
- [55 Stiles](#)

10.1 Introduction

Ministry of Forests' recreation trails, like recreation sites, are managed for the public. In the province of British Columbia there are many players involved with recreation trails ([Section 1.1](#)). Ministry of Forest (MoF) recreation trails should complement the programs of other agencies and the private sector by providing recreation opportunities that are not available elsewhere.

The overall image created by MoF recreation trails should be one of quality rustic trails in natural settings. Trailheads, and structures (bridges, cabins, signs, etc.) must complement and blend with the natural setting, rather than contrast or dominate it.

This chapter focuses on recreation trail management and defines the Ministry's role in providing part of the spectrum of recreation opportunities for the public. It sets out the management procedures for this very visible and capital-intensive component of the recreation program. An overview of recreation trail management is shown in [Table 1](#). This table identifies the phases

associated with recreation trail management and the purpose, outputs and responsibilities of each of those phases.

[Table 1: An Overview of Recreation Trail Management](#)

[[Top](#)]

10.2 Trail Planning

Planning, development and maintenance of trails is the responsibility of districts and regions, and takes place within the context of strategic and operational planning (e.g., higher level plans, district recreation plans).

Subsequent to this overall land and resource management planning process, recreation trails are developed according to the standards and the desired recreation image established in this chapter.

Recreation trail planning consists of the following phases:

- trail concept planning;
- trail establishment; and
- trail assessment.

Comprehensive and detailed planning prevents mistakes, and saves time and money in the long run; therefore, the planning process also extends into trail design, construction and maintenance.

[[Top](#)]

10.2.1 Trail Concept Planning

Trail concept planning is the first phase in the development of a recreation trail. At this stage, broad objectives and the general characteristics of the trail are determined. The concept plan looks to any pertinent plan(s) for direction (especially higher level plans and the district recreation plan).

The concept plan takes many factors into account, including:

- user group requirements;
- ROS class;
- recreation features (including landscape features and existing recreation facilities);
- management requirements; and
- anticipated needs for trail construction and maintenance.

Recreation Opportunity Considerations

Consideration of the setting is important not only in the development of the trail concept plan, but also in the evaluation of the existing trail opportunities. The concept plan should:

- **identify the particular trail development relative to the existing types of trail opportunities present.** For instance, high priority may be placed on developing a cross-country ski trail in a semi-primitive, non-motorized setting if most of the trails in a district are located in semi-primitive motorized or roaded settings with ATV, equestrian and snowmobile use being the dominant trail activities.
- **generally define trail characteristics that reflect the ROS class and the abilities and needs of the anticipated user groups.** For example, it would be inappropriate to consider developing a long and arduous hiking trail in a roaded or rural setting where heavy day use from a broad population base was the primary anticipated user group.
- **sometimes allow for challenging trails in frontcountry areas with roaded or rural ROS designations.** For instance, steep single-track mountain bike trails for downhill riders may be appropriate between roads providing uphill connections.

The following ROS setting considerations on trail development have been adapted from the *Trails Management Handbook* produced by the US Forest Service. These considerations should be addressed at a broad overview level consistent with the development of a concept plan.

Social Setting

- Type of use: the mode of travel, mix of user groups and relationship between trail activities, particularly motorized and non-motorized.
- Volume of use: anticipated numbers and frequency of encounters between user groups, and the impact of that volume on the physical setting.

Physical Setting

- Location and overall design of the corridor: the trailhead facilities and associated structures in relation to the ROS class.
- Visual management: the viewshed of the trail route and the visual impact of the trail itself on the landscape.

Management Setting

- Management of trail activities and use relative to any necessary regulatory control, such as signs or barriers (trail location and design may also help to meet these needs).
- Trail stewardship: good stewardship as evidenced by good quality construction and maintenance shows management concern and promotes responsible use on the part of the trail user.
- Compatibility of other resource management activities (e.g., harvesting) with the intended type of trail use; the following may help to minimize potential conflicts:
 - trail location and design;

- maintaining visual management practices, including adherence to visual quality objectives; and
- timing of either the resource management activity or trail use to avoid peak conflict periods (may involve seasonal trail use restrictions).

[[Top](#)]

10.2.2 Trail Establishment

Trail establishment is the legal process of identifying a trail corridor, establishing a map notation or map reserve over the area, distributing referrals to other agencies, and notifying the public.

Trail establishment procedures are covered in detail in *Higher Level Plans: Policy and Procedures*, a Forest Practices Code publication.

[[Top](#)]

10.2.3 Trail Assessment

A detailed assessment of the trail and the surrounding area is an integral part of the planning process. Examining the natural features of the landscape relative to the expected use can minimize environmental disturbance and, in most cases, enhances user satisfaction. In order to plan in this fashion, the aesthetic features of the trail area, as well as the physical, biological and landscape features, must be well-understood and documented.

Trail Assessment involves three basic stages:

- Pre-field investigation (incorporating inventory information);
- Trail evaluation; and
- Interpretations of carrying capacity and limitations to trail development.

Each of these stages is discussed below.

i) Pre-field Investigation

Gather as much resource information for the trail and surrounding areas as possible. This includes maps of terrain, soils, vegetation, forest cover, wildlife and aquatics, and information on climate and archaeological or historic sites. Recreation inventories of features and also provide valuable input at this stage.

Preliminary investigation will avoid duplication of effort in the field, will help identify areas of particular concern along the route, and will dictate the type and extent of additional information needed later on. For example:

- terrain maps will identify surficial materials and may indicate hazardous geologic processes, such as avalanche or failing slopes;
- soils maps include information on soil conditions and indicate areas of organic and poorly drained soils, as well as identify slope classes;
- vegetation and forest cover maps may give an indication of understory density and sensitive vegetation areas;
- wildlife maps may indicate areas of potential conflict during the intended season of use, such as caribou calving or grizzly bear feeding areas (knowledgeable experts may need to be consulted); and
- archaeological and historic-use maps may indicate that an impact assessment will be required (knowledgeable experts may need to be consulted).

Wherever possible, use aerial photos and topographic maps as base maps for recording field information, and for the trail layout and design presentation package. Scales of 1:20 000 or less are most appropriate for detailed trail route analysis. If such scales are not available, 1:50 000 scale maps and photos may be enlarged.

The following sources can provide additional information:

- *Maps BC*: Air photos and topographic maps, along with published terrain, soils, vegetation, forest cover, recreation features, aquatic and wildlife maps, and climatic record information;
- *Archaeology Branch*: Archaeological and historic site information.

Using this information, a preliminary trail route may be plotted onto a base map, tying into recognized points, such as saddles, creek crossings or rock bluffs.

ii) Trail Evaluation

Trail evaluation is an on-the-ground assessment of the area's potential for recreation trail development. The first step in trail evaluation is to determine the preliminary trail route. Procedures for determining the preliminary trail layout in the field are taken from the *Manual for Trail Construction and Maintenance*, produced by the Federation of Mountain Clubs of British Columbia:

Trail Evaluation Procedures

- Take copies of visual and recreation features maps, carrying capacity maps, air photos and topographic base maps to the field. Locate the on-the-ground control points shown on the preliminary route map.
- The intervening sections of the trail should fit between the final chosen control points as well as possible.
- Mark all the trail lines with brightly coloured flagging tape. Place the flagging at close intervals on living trees, preferably around the trunk, tied loosely so that it can be removed and placed elsewhere if a better route is selected.

- Travel the route at least once in both directions at a time of the year when there is no snow on the ground. In areas having a moist or wet climate for at least part of the year, the route should also be examined during the wet season to identify drainage problems that may not be apparent at other times.
- Ideally, three to five people should participate in the preliminary marking and should space themselves out so that each person can be seen and heard by the next. Working together, keep the route as direct as possible. Tape should be placed so that the next two tapes can be seen from any aspect (i.e., those ahead and behind).
- When establishing the route, the designer must constantly consider all pertinent recreational and environmental factors.

Physical and Social Elements

After a preliminary trail route has been identified, the following physical and social elements should be evaluated in the field:

- topography
- soils and drainage
- vegetation
- aspect
- hazards
- natural features
- aesthetics
- access
- potential recreation activities
- ROS classification
- degree of degradation
- limiting factors
- current public use of site/expected use
- water supply/water bodies
- Visual Quality Objectives (VQOs)
- impact on future resource development
- elevation, annual precipitation, biogeoclimatic zones

Another aspect of field investigation for trail development is the evaluation of specific sites along the route that may be used for related activities. These include picnic sites, campsites, toilets, trailheads, viewpoints and interpretation sign areas. Such site considerations are discussed in [Chapter 9](#).

Amount of Time to be Spent

The amount of time spent on each of these steps will depend on the expected use and importance of the trail route to be developed. A high-use trail in a high-profile location will require the most thorough pre-field investigation and on-the-ground evaluation.

iii) Interpretation of Carrying Capacity

The amount and type of expected use on a trail will influence the layout and design, as well as construction and maintenance costs.

Defining Carrying Capacity

Carrying capacity may be defined as *the amount of use an area can sustain without undue environmental degradation*. It is the physical and biological carrying capacity of the trail as identified by terrain, soils, topography, vegetation, forest cover, wildlife and climatic factors, along with the type and intensity of trail use that determines the overall potential impact on the environment.

Recreational use of an area can diminish the quality of both the natural environment and the recreation experience. Concern about overuse causing negative impacts on the ecological and social environments of an area has led managers to try to establish carrying capacities.

*Focus is on the **Amount** of Use*

This approach has focused attention on the amount of use and the search for a specific number of people that can be allowed to use an area without causing unacceptable changes to the natural environment or the recreation experience. As the environmental and social conditions along the trail route change, the carrying capacity also changes. Areas along a trail where use is concentrated, such as the trailhead, camping and picnic sites, and interpretive signs, will incur a greater environmental impact than the trail route itself.

Negative Impacts

Some of the more commonly cited negative impacts on recreation resources include:

- the loss of vegetation on trails and campsites;
- camping debris;
- forage impacts from pack animals;
- soil compaction around trees;
- human suppression of fires;
- mining, fishing and hunting; and
- the introduction of non-native species, as well as water and air impacts from both on and off-site human activities.

Other impacts can affect the quality of a recreation experience, such as a preference for solitude while hiking and camping.

Problems with Using Carrying Capacity

Because of these potential impacts, backcountry and wilderness managers have recognized that a key challenge is finding means to effectively protect both physical and social settings.

The carrying capacity of an area can vary depending on the management objectives. An acre of city park can accommodate more people than an acre of wilderness. Secondly, much of the adverse impact of recreational use is not the result of too much use, but rather the kind of use, the behaviour of visitors, and the timing and distribution of use.

The amount of impact caused by a specific number of users can be affected by the activities of the user, the user's level of skill, the pattern of use and other factors. Furthermore, the amount of impact is not always directly related to the amount of use. A little use in a new area may cause a lot of impact, while a lot more use may cause only slightly more impact. Because of these problems, it can be very difficult to identify a specific number as an area's "carrying capacity."

The traditional carrying capacity approach to managing backcountry and wilderness often leads managers to institute a system of use rationing, which is a fairly heavy-handed management tool. The search for a single, magic, carrying capacity number can also misdirect the manager's attention to numbers instead of trying to correct specific problems.

Indications of Excessive Impact

Trail design, construction and maintenance must proceed in consideration of the carrying capacity and anticipated use so as not to exceed the desired level of impact.

Recreational use exceeds this level of impact when:

- environmental alteration occurs to a degree that is unacceptable to management and user requirements;
- an inconvenience or safety hazard exists for the user; and
- an excessive cost is incurred to maintain the quality of the site for a specified use.

Limits of Acceptable Change

The Limits of Acceptable Change (LAC) concept is based on the premise that changes to the ecological and social conditions of an area are going to occur due to both natural and human factors. Acceptance of this premise immediately redefines the traditional question about carrying capacity from "*How much use is too much?*" to "*How much change is acceptable?*"

*The real concern is the **effects** of use, not how much use is occurring*

The goal is to keep the character and rate of change due to human factors within acceptable levels. Or to put it another way, to decide what kind of environmental and social conditions are acceptable, then prescribe actions to protect or achieve those conditions. "*The LAC process recognizes that the real concern is the effects of use, not how much use is occurring.*"

LAC Components

The LAC planning system consists of four major components:

1. the specification of acceptable and achievable resource and social conditions;
2. an analysis of the relationship between existing conditions and those judged acceptable;
3. identification of management actions judged to best achieve the desired conditions; and
4. a program of evaluating management effectiveness.

For more detailed information on the current application of LAC, contact recreation staff in the regional offices or Victoria.

Trail Development Questions

The *Trail Manual* produced by the Canadian Parks Service suggests the following questions be asked prior to trail development:

- what is the desired level of use?
- what will be the extent of detrimental impact upon the environment? and
- is this level of impact acceptable?

These questions are best answered with thorough knowledge of the environmental conditions along the proposed route. If the level of impact is not acceptable, then alternative solutions include:

- a change in the trail location to a less sensitive area;
- construction measures that minimize degradation, including tread surfacing, drainage control and barriers; or
- changing the type of use (e.g., developing a walking trail rather than an equestrian trail).

[[Top](#)]

10.3 Trail Design

Trail design is the final phase of the trail planning process. Although some design decisions will have been made during the concept planning and assessment phase, the design process pulls together all the requirements into a final, field-checked trail plan that successfully translates the trail concept plan.

Figure 1: Trail Design Process

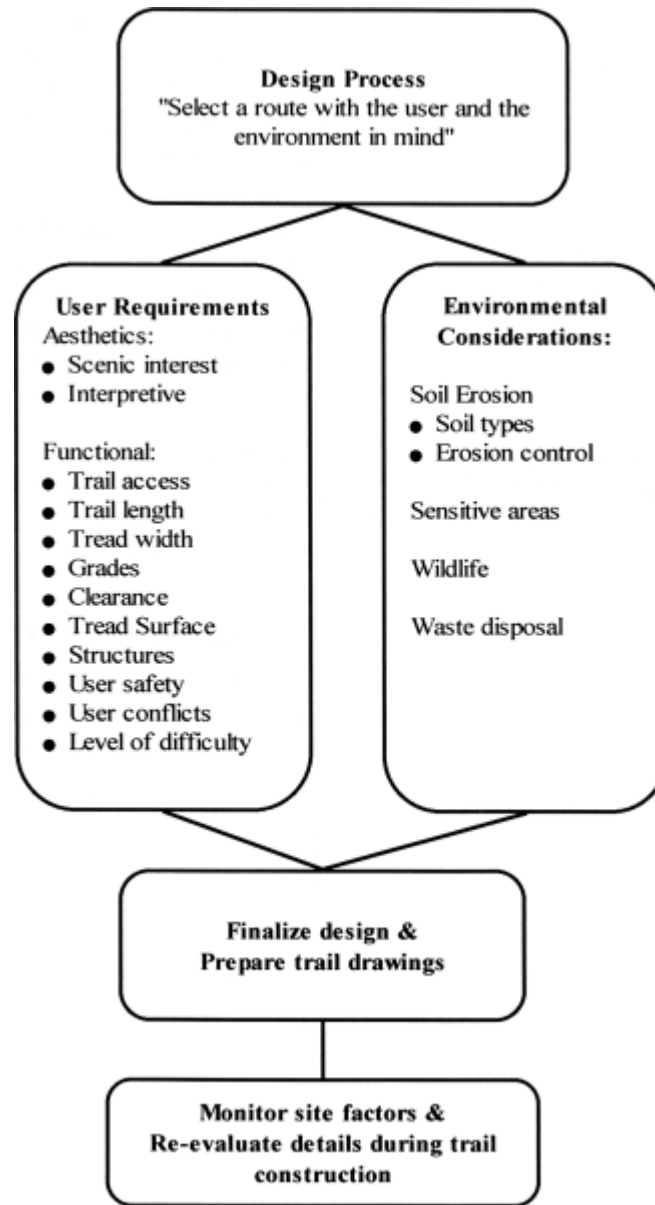

[[Top](#)]

10.3.1 Principles of Trail Design

Well-designed trails create a harmony between user and location.

While trails may provide access to a destination, they can also provide the trail user with a sense of enjoyment and fulfilment throughout the journey. In many situations, trails are not taken to reach a particular goal; rather it is the joy of using the trail and savouring the trail environment that is the primary recreation experience being provided.

Many day-hikers, for example, fall into this category, seeking a trail which matches their ability level and provides an appropriate balance of effort and reward. The result is a day well spent, and a renewed appreciation of the forests passed through, views enjoyed and wildlife glimpsed.

This section deals with design guidelines that relate to all types of trail development. The Canadian Parks Service's *Trail Manual* identifies *user requirements* and *environmental protection* as the two major areas of design considerations. The following information has been taken almost entirely from that manual.

Final decisions should be made in the field

Structural items, such as bridges or retaining walls, may need to be designed in the office, and major structures may require advice from engineering staff.

The following, however, should be addressed during field visits:

- clearing, tread widths and types of materials to be used;
- trail length, location, environmental protection measures; and
- number and location of construction requirements, such as switchbacks, boardwalks, bridges, waterbars, and culverts.

[[Top](#)]

10.3.2 User Requirements

Trail location and design, including the structures provided along the route, should meet the needs of the anticipated user group as much as possible.

User requirements include:

- an aesthetic component, which provides a measure of satisfaction through the scenic and interpretive aspects of the trail landscape; and
- a functional component, which provides an ease of movement, sufficient comfort and no worries about the safety aspects of the trail.

These aesthetic and functional requirements must be considered in relation to the interests and abilities of the users.

Construction standards for factors related to trail type will be presented later in this chapter.

Aesthetic

Scenic Interest

Create a variety of views including full vistas, partial openings and closed forest canopies. Use natural openings, such as meadows or marsh edges, for interest and rest areas. Enhance visual interest by providing brief views of a feature, such as a waterfall, before the user is next to it or passes by.

- Align the trail near recreation and interpretive features or wildlife viewing opportunities.
- Design the trail to take advantage of topographic and biological variety; for example, along ridge tops and valley bottoms. Curved sections that fit into existing landforms, such as along ridge crests or the edge of benches, are usually more interesting than long straight sections.

Interpretive Opportunities

Gaining an understanding of the environment of the trail route increases user interest and satisfaction. This should be considered in all trail design and development. However, in the case of interpretive trails, these considerations will largely determine the exact trail route and design in order to facilitate communication with the user through the use of guided tours, interpretive signs, brochures, etc.

All trails, wherever possible, should take advantage of views and proximity to natural features, such as waterfalls, outstanding vistas, meadows, large trees, geologic features, etc. Potential overriding considerations, however, such as known bear feeding areas or public safety concerns near cliffs and waterfalls, must also be kept in mind.

Functional

Trail Access

Trailheads and parking areas are an essential component of trail design. These facilities should reflect the trail design itself, the type of trail activity, the ROS setting and the anticipated user volume.

- Where several trails begin in the same area, provide a common trailhead as much as possible.
- Consider separate trailhead and parking areas for different user requirements, such as hiking and equestrian.
- Incorporate snow removal and winter maintenance practices in designing access to winter use trails.
- Consider use of non-licensed vehicles, such as trail bikes or snowmobiles, in designing access for motorized trail use (exclude public or private roads that require possession of a licence).
- Consider additional parking space for larger vehicles, such as trailers or stock trucks, as well as unloading ramps and the safety of unattended vehicles.

In all cases, trailhead and parking areas should be developed using visual management and design practices that minimize their effect on the trail and trail users.

For a more detailed description of trailheads and structures, refer to [Chapter 9](#).

Trail Length

Trail length depends on the type of trail activity, the ability and interest level of the intended users, and the existing terrain conditions of the trail route. Day use bicycle and ski trails will be longer than day use walking trails. Trails for experienced hikers will be longer than those for less experienced hikers.

Tread Width

The width of the trail tread varies in consideration of the intended trail activity, variable terrain conditions, and whether travel is one-way or two-way.

- Backcountry (semi-primitive ROS) hiking trails will be narrower than day use (roaded ROS) walking trails because the volume of use will be less and site modification should be kept to a minimum.
- In rough terrain, tread width may be narrow, requiring single-file use, whereas in gentle open terrain, tread width may be wider, allowing users to travel two or more abreast.

Grades

The slope factors that affect trail difficulty are:

- the degree of slope;
- the length of sustained grade; and
- the proportion of uphill to downhill and level sections along the trail.

The slope or grade of a particular section of trail is expressed either as a ratio, as a percentage of vertical to horizontal distance (referred to as the rise-to-run), or as degrees of angle. The figure below shows various gradients in terms of ratio, percentage and degrees. On a 1:4 grade, there is a *rise* of 1 to a *run* of 4.

Figure 2

Slope Gradients

- 1 1:1 - 100% - 45°
- 2 1:2 - 50% - 27°
- 3 1:3 - 33% - 18°
- 4 1:4 - 25% - 14°
- 5 1:5 - 20% - 11°
- 6 1:10 - 10% - 6°

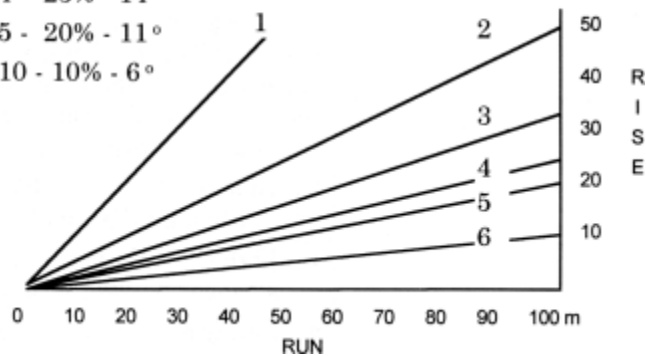

As in trail length, the type of trail activity, terrain conditions and user ability are the main areas of consideration.

- A variety of gradients, with gentler sections between steep climbs, is preferable to long, sustained grades.
- Switchbacks, steps or ladders may be considered for small sections of very steep slopes.
- For most trail uses, a 20% maximum grade over a maximum distance of 30 metre is desirable. However, if only a few steep areas occur along the entire length of the trail, a greater maximum grade would be acceptable. In general, a slope of 10% is desirable for those trails that steadily gain vertically over a long distance.

Right-of-way Clearing

The width of vegetation clearing should only extend far enough to provide safe and unimpaired movement along the trail. Unnecessary clearing reduces the aesthetic value of a trail (see [section 10.4.2](#) for further details).

- Branches, shrubs and small trees should normally be removed from the right-of-way.
- If tread surfacing is not used, the existing cover of small plants, turf or surface material should remain intact to help prevent erosion and to keep a natural appearance.
- Trails should be routed around large trees and shrubs or plants of interest.

Trail Tread Surface

The trail tread may consist of existing surface materials, or it may be constructed from materials added to the trail bed once the leaf litter and surface soil have been removed.

Several types of surfacing materials may be used (*for a detailed discussion of various tread surfaces, see [section 10.4.2](#)*). The selection depends on user requirements, aesthetic and

ecological compatibility, and the costs of construction. Wood chips or gravel may be used for a hiking trail, but special needs trails may require compacted crushed stone. The type of surfacing used should blend into the landscape and reflect the setting. Generally, use of indigenous materials causes less ecological concern and is less costly.

Given suitable soil conditions, foot trails can be resurfaced with only a minimum of material.

- Light gravel (25 mm thick) rolled or tamped into the trail surface should give adequate durability.
- Sandy soils may require mixing with a small portion of clay or limestone dust to bind the soil particles.

Less suitable soil conditions, anticipated heavy use trails, or special needs trails require more substantial surfacing.

- Wet soils require a barrier between the soil and the surfacing material so that the surfacing is not compressed and lost into the soil.
- Fir or spruce branches may be used in areas that are not too muddy.
- Synthetic fabrics that allow passage of water and yet separate the surfacing material may also be used, but these are costly.
- On very wet muddy areas, a layer of logs may be required.

Structures

Structures commonly used along trails include bridges, boardwalks, steps, signs and barriers. Their design must take into consideration trail activity, user volume and safety, terrain conditions and setting, and the aesthetic experience being provided.

Structures must be appropriate for the experience being provided. For example, a well-constructed bridge with handrails and steps may be inappropriate in a backcountry setting where trail users are experienced and expecting a primitive setting. Similarly, a single log bridge in an area used by families may not be suitable.

Detailed drawings of standard structures are shown throughout the rest of this chapter.

Bridges & Boardwalks

Bridge location and design should take into consideration stream flow characteristics, bank and stream bed erosion potential, fish habitat, peak run-off periods, snow loads and ice conditions. Adequate clearance must be provided on navigable watercourses to allow for boats.

The functional requirements of the trail will determine a bridge's structural strength, width, need for railings, and the type of construction material used for decking. Bridges on equestrian trails or in areas of moose wetland habitat should be strong enough to support large animals.

Steps

Steps are used on short, steep trail sections, particularly in high-use locations, to ensure user safety and help prevent erosion. On trails where a wide range of users is expected, step design should take into consideration comfort and safety factors. A series of short flights of 14 steps or less with ample landings in between is preferable to a single, long flight.

Barriers

Barriers may be necessary in trail design if the trail location itself does not provide adequate safety from hazardous situations, such as cliff edges or rapids. Barriers may also be necessary to protect sensitive areas from traffic or to prevent inappropriate use (e.g., vehicle access to non-motorized trails or mountain bike use on hiker-only trails).

Railings and walls form barriers that vary in height depending on their purpose. Stiles and dodgeways form barriers that may be used to block motorcycle access to foot trails. Bollards placed across the entrance to bicycle paths will block access by cars and trucks. As with most other structures, barriers may be constructed of logs, timbers, stones or boulders, depending on the availability of materials. Ditches across a trail may also be used to control access.

User Safety

User safety considerations include hazardous terrain features (such as cliffs, danger trees, avalanche zones or swift rivers) and hazardous wildlife areas (such as known bear feeding areas). Safety precautions should suit intended user ability and attitudes, as well as the environment. Overly protective trails with excessive railings and barriers downgrade the user experience and the natural character of the landscape.

Trailhead information signs or brochures outlining potential hazards and necessary precautions are essential and, in some instances, may reduce the need for safety structures on trails. Where serious hazards exist during certain seasons, such as grizzly activity or avalanching, trails may be closed for a period, or users directed to alternate trails.

Trails should avoid known areas of bear habitat (e.g., soapberry or equisetum communities, avalanche slopes, or fish spawning areas) and should be designed so that surprise encounters are unlikely. Avoid noisy waterways or sharp bends in densely vegetated areas. Assessment by a professional biologist is recommended in areas frequented by grizzly bears.

User Conflicts

Wherever possible, single-use trails are the best choice for both trail builders and trail users. Design and construction can be focussed on particular requirements, and one user's experience will not be adversely affected by the presence of another.

Hikers, mountain bikers, and horse riders often find themselves sharing trails. On Forest Service trails, self-regulation (assisted by signing and user education) is the practical option to strict

enforcement. A user Code of Ethics designed for cyclists, pedestrians and equestrians has been developed by the Outdoor Recreation Council of BC.

Level of Difficulty

Level of difficulty is a subjective rating based on many variables, including the fitness and attitude of trail users. It is also a very useful consideration when planning a trail for a particular user group.

A level of difficulty rating will primarily reflect trail grade and distance; but a trail rated as "moderate" by a group of day hikers carrying only lunches may be a strenuous trail for backpackers with full loads.

Recreation trail planners will need to consider such variables and be flexible with design standards in order to create intended recreation opportunities. Level of difficulty is based on the hardest element of a trail; i.e., a moderate trail with a single difficult section would be rated "difficult."

[[Top](#)]

10.3.3 Environmental Considerations

Trails that adversely impact their environment will not only have a low aesthetic value for their users, but also a high maintenance cost to the supporting agency. Trails, therefore, should be designed with consideration both for their environment and for their users.

- Where trails cannot be located away from sensitive soils or poorly-drained areas, provide for boardwalks, tread surfacing or trail drainage.
- Trail clearing should be skilfully done and not be excessive. Users will not enjoy travelling a cleared swath when all they require is reasonable passage through an interesting forest area.
- In areas of heavier use, or in sensitive areas, toilets must be provided.
- Trail routing, signing and appropriate facilities can help direct users to areas hardened to withstand the impacts, and away from areas that will show the impacts of accumulated use, such as lake shores and alpine meadows.

Soil Erosion

Erosion is a natural process in which soils are worn away by the action of wind, water, glaciers and other natural phenomena. On trails, this natural process is agitated by soil compaction and the almost constant churning agitation of hiking traffic. Mountain bikes and horses especially cut into soft and wet trails, greatly increasing the erosion process.

Soil erosion is one of the most frequent types of environmental disturbance on trails. It affects the longevity and usefulness of trails, increases maintenance costs, detracts from visual quality, degrades plant and animal habitat, and may affect safety.

Effects of erosion include:

- loss of surface materials;
- root exposure, resulting in physiological stress to plants and, in the case of trees, susceptibility to windfall;
- stream sedimentation, resulting in damage to spawning beds, increased turbidity, and adverse effects on flow regime and stream flora and fauna;
- contamination of water supplies; and
- failing slope through slides and slumping.

Soil erosion is likely to occur on trails where surface runoff is not properly controlled, where trail grades are too steep, and where surface water is not diverted off the trail.

Soil Types

Some soil types are more susceptible than others to erosion.

Fine-textured soils:

- dry out slowly after rains;
- become muddy with trampling in wet conditions;
- are susceptible to compaction and subsequent surface water ponding in level areas; and
- are susceptible to erosion, depending on slope and moisture conditions.

Coarse-textured soils:

- dry out quickly after rains; and
- have poor nutrient availability, making vegetation regeneration difficult.

Shallow soils are:

- susceptible to erosion, particularly on slopes.

**Table 2
Summary of soil indicators for
evaluation of a proposed trail installation**

Conditions	Conditions Posing Slight Limitations	Conditions Posing Moderate Limitations	Conditions Posing Severe Limitations
Soil Wetness	Depth to seasonal high water table more than one metre; well-drained to moderately well-drained	Depth to seasonal high water table 0.3 to 1 metre; excessively drained	Depth to seasonal high water table less than 0.3 metres

Soil Texture	Particle mixture of sand, clay and silt; gravel is 20-50% of content	High sand content; gravel content is 20-50% of content	High clay content; no gravel
Soil Structure			Hardpan is less than 0.3 metres from soil surface; peaty, mucky soils
Soil Depth to Bedrock	> 1 metre	0.5-1.0 metres	< 0.5 metres
Slope	0 - 0.5% (< 1:20)	5 - 20%	> 20% (> 1:5)

Erosion Control

The design process can incorporate recommendations to minimize soil erosion. Details of the prescriptions, and where they occur, are described in the final trail plan.

Locate trails in areas least sensitive to erosion. If this is not possible, minimize erosion by using appropriate construction measures.

Ensure proper control of drainage water on slopes by:

- avoiding steep sections susceptible to water runoff;
- orienting trails across slopes on the diagonal, or use switchbacks to climb steep slopes;
- incorporating natural grade dips into the trail surface so that drainage is diverted at frequent intervals;
- using steps or ladders on steep slopes, making sure drainage water is diverted from the top of steps; and
- sloping the cross-section of the trail tread approximately 2%, or 4 cm per 1 metre of tread width to redirect water.

Drainage Across a Trail

Depending on the level of surface runoff, trails can be designed to help water flow off the surface and/or be intercepted and channeled away.

When surface runoff is low, it can run directly across the trail surface (figure 3). When surface runoff is high, the tread cross-section should be crowned, with a ditch on the uphill side to lead water to grade dips, culverts or waterbars (figure 4).

Figure 3: Drainage across a trail (low runoff)

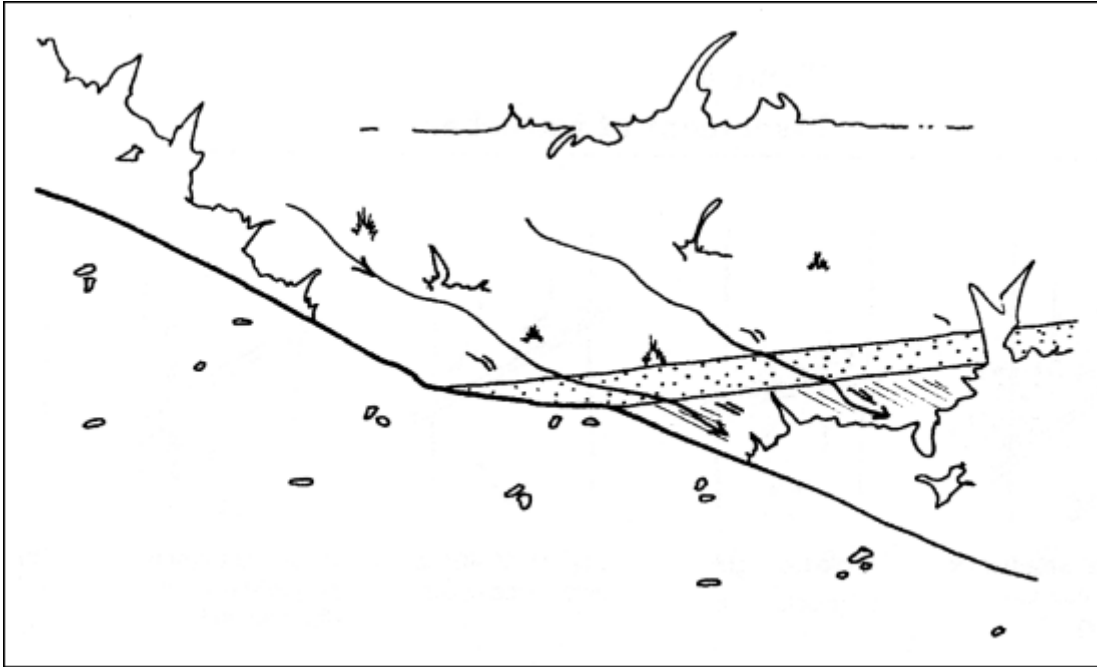
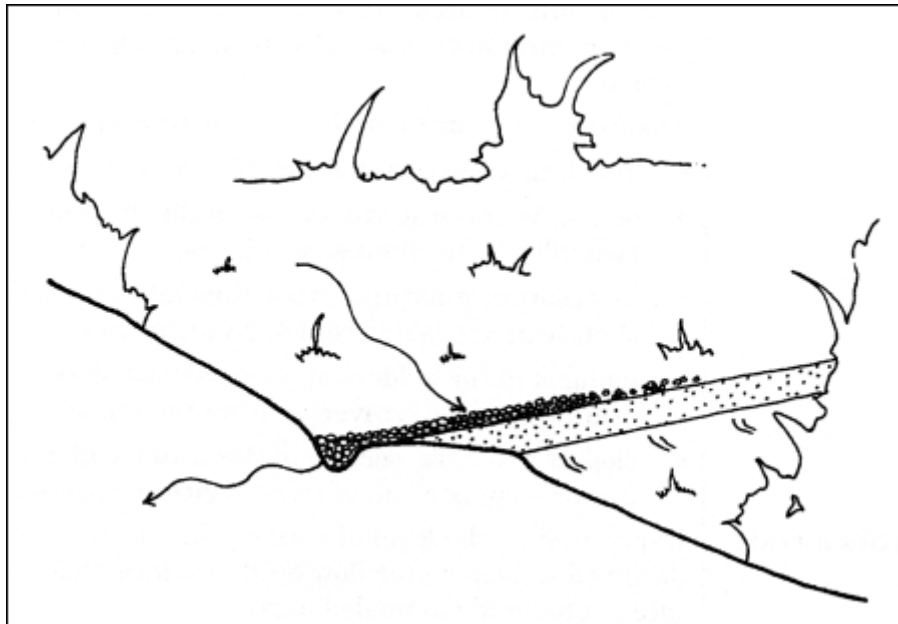

Figure 4: Drainage intercepted (high runoff)



Waterbars

Waterbars (or cross drains) intercept water running down the trail tread and direct it off the trail. When cross-sloping the trail tread and grade dips are not adequate to control runoff, waterbars can be an effective solution. Trail design plans will indicate sections requiring waterbars and the maximum space between them.

Figure 5: Placement of waterbars

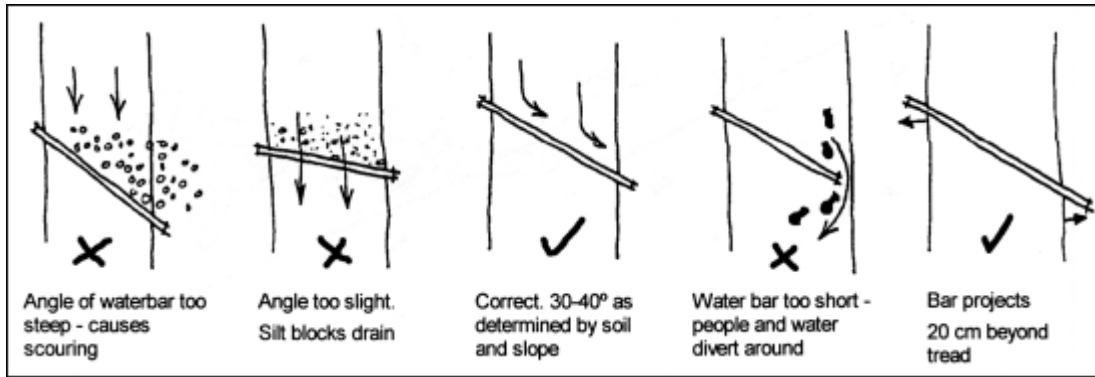
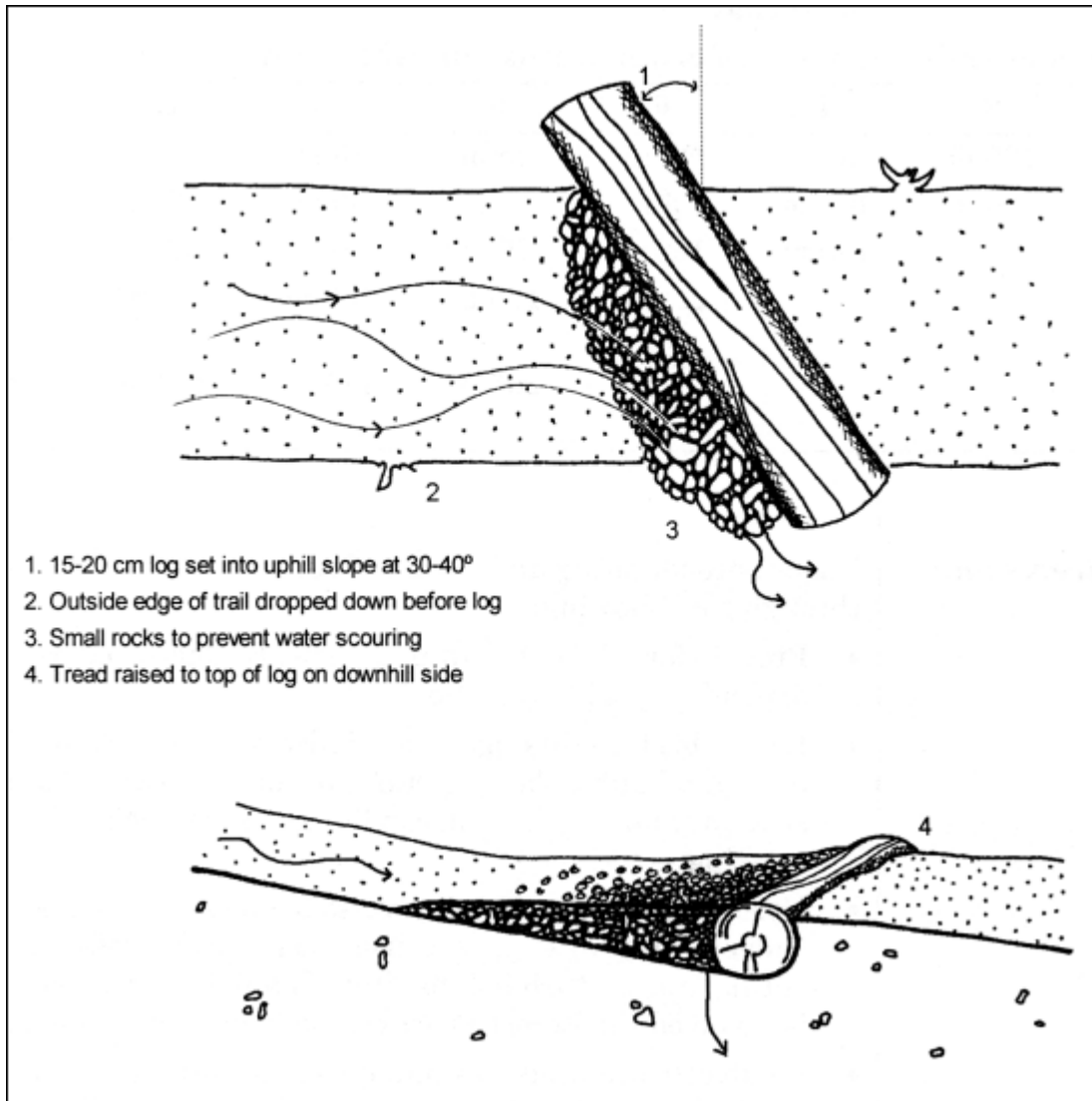

Figure 6: Log waterbar



Waterbars may also be constructed of stones 15 cm or greater in diameter and placed across the trail in the same position as the log waterbar illustrated.

The following table gives recommendations for the frequency of cross drains on different surficial materials and on different slopes.

Table 3: Waterbar frequency table
Recommended spacing of cross drains and water bars (meters)

Grade in %	2	4	6	8	10	12	15
Loam	100 m	50 m	30 m	25 m	15 m		
Sandy clay	150 m	100 m	75 m	50 m	30 m	15 m	
Clay		150 m	100 m	75 m	50 m	30 m	25 m
Gravel or rounded rock			250 m	150 m	100 m	75 m	50 m
Shale or angular rock			275 m	200 m	125 m	100 m	75 m

Siting of Culverts and Bridges

Ensure proper siting and design of culverts and bridges through the following:

- provide for adequate drainage flow. Bridge specifications depend on peak flows and flood cycles;
- locate bridge crossings to minimize disturbance to stream beds and banks. Those sections of the waterway that are straight, and where bank conditions are stable, are best for crossing;
- use bridges rather than culverts to cross large streams. Culverts may alter flow, cause downstream erosion or silting, and disturb fish habitat. If a fish-bearing stream is involved, the Forest Practices Code must be followed; and
- If culverts are used on small drainage ways, they should be of an adequate size and set at a level that will not interfere with drainage. Rocks should be set around the ends of the culvert to stabilize the fill material and hide the ends of the pipes. Surfacing over the pipes should be a minimum of 10 cm.

Trail Shortcutting and Side-Trampling

These poor user practices promote soil erosion. They occur when users wander off the trail or make shortcuts that cause vegetation and soil trampling. Users take shortcuts where the trail is unsafe or an easier route is visible. Muddy conditions, erosion and deadfalls also force users off the trail tread.

The design process can incorporate recommendations to minimize shortcutting and side-trampling:

- widen trails at feature points, view sites or interpretive displays where use is expected to be heavier;
- define trail edges clearly by using logs or rocks;
- raise the trail tread by using log stringers, tread surfacing or boardwalks;
- use landforms or vegetation to block potential shortcuts;
- move the trail location to the shortcut route if it is superior to the original route;
- close-off potential shortcuts by placing rocks, branches, fallen trees or new plantings to obstruct access;
- use signs requesting that users stay on the trail, or
- minimize the use of switchbacks in trail construction; the use of alternate routes or using steps or ladders may be possible. Shortcutting is not as common in areas of dense vegetation.

Special Areas with Sensitive Features

Special areas with sensitive features include any locations where the presence of humans, or the disturbances associated with building a trail, could impact negatively on the special features. Such features include archaeological sites, areas where rare plants are growing, bird nesting sites and wildlife habitat (see below).

Most wet areas, such as lakeshores, bogs and marshes, are particularly sensitive to being disturbed. If any such area cannot be avoided, and is not critical habitat, it can be crossed using a raised trail bed supported by stringers filled with woodchips. Boardwalks can be constructed across standing water and areas of wet organic soils.

If there are fragile plant communities next to the trail, define the trail edges using rocks or logs.

Wildlife

Areas with identifiable wildlife hazards or potential wildlife conflicts should be identified early in the trail design process - and avoided.

Wildlife hazards occur in those areas where the animals themselves may cause hazards to users, such as areas of bear or rattlesnake concentrations.

Wildlife conflicts can occur in areas such as:

- important waterfowl or marine bird nesting, staging or wintering areas;
- big game rutting, birthing, wintering, migrating or mineral lick areas (may also pose a hazard to the user);
- important fish spawning or rearing habitat, which may be damaged by the removal of trees or shrubs along a river where a trail is proposed; and
- habitat of special importance to rare or endangered species.

Waste Disposal

Disposal of all waste matter is an important consideration in trail design. Litter along the route, garbage associated with overnight camping, and horse and human excrement not only detract from the quality of the trail corridor, but are a health and safety concern. Broken glass, cans, bottle caps and plastic bags are also hazardous to wildlife. Bears that become habituated to human food become a problem.

The design process can incorporate the following recommendations to minimize waste disposal problems:

- an effective management practice is to educate users and implement a "pack-in-pack-out" policy;
- where horse traffic is expected to be heavy, other types of trail use during the same season should be avoided; and
- if designated campsites are located along trail routes, site design considerations must be applied to the use of toilets.

[[Top](#)]

10.3.4 Design Considerations

The following two figures show both poor and good trail design.

In addition, a trail system should use different layouts to satisfy a diversity of recreational needs. Careful design will provide trails for different users with differing expectations.

Figure 7: Poor trail design

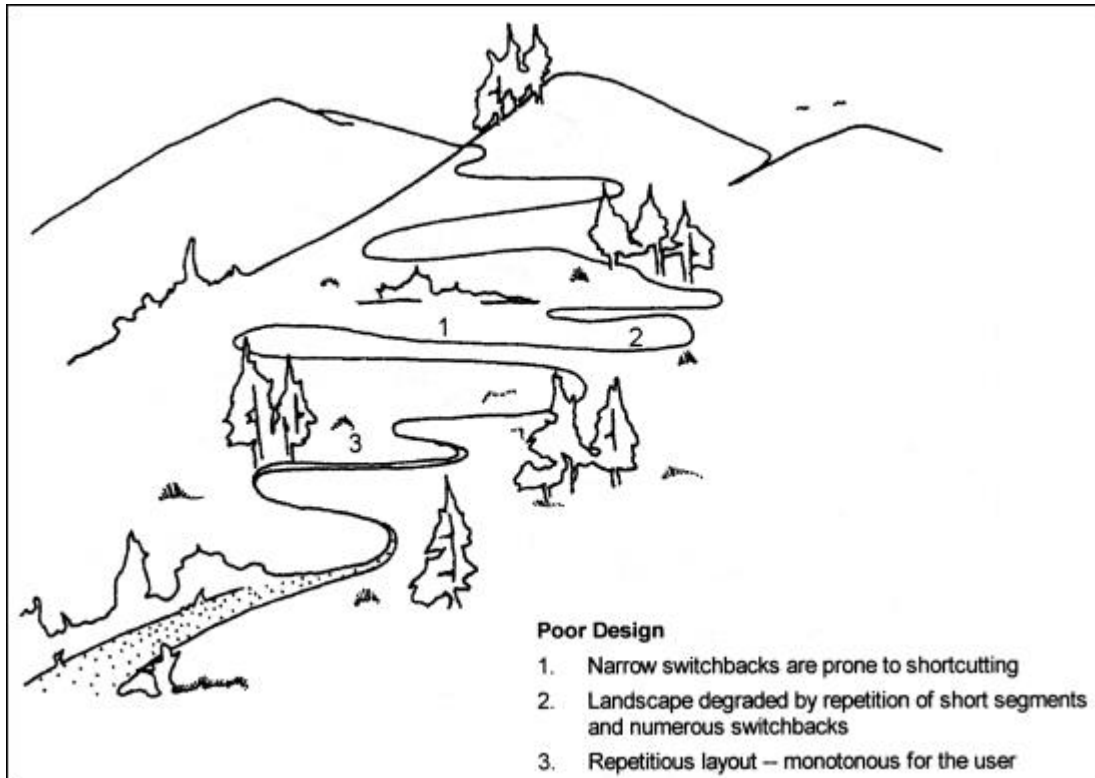

Figure 8: Good trail design

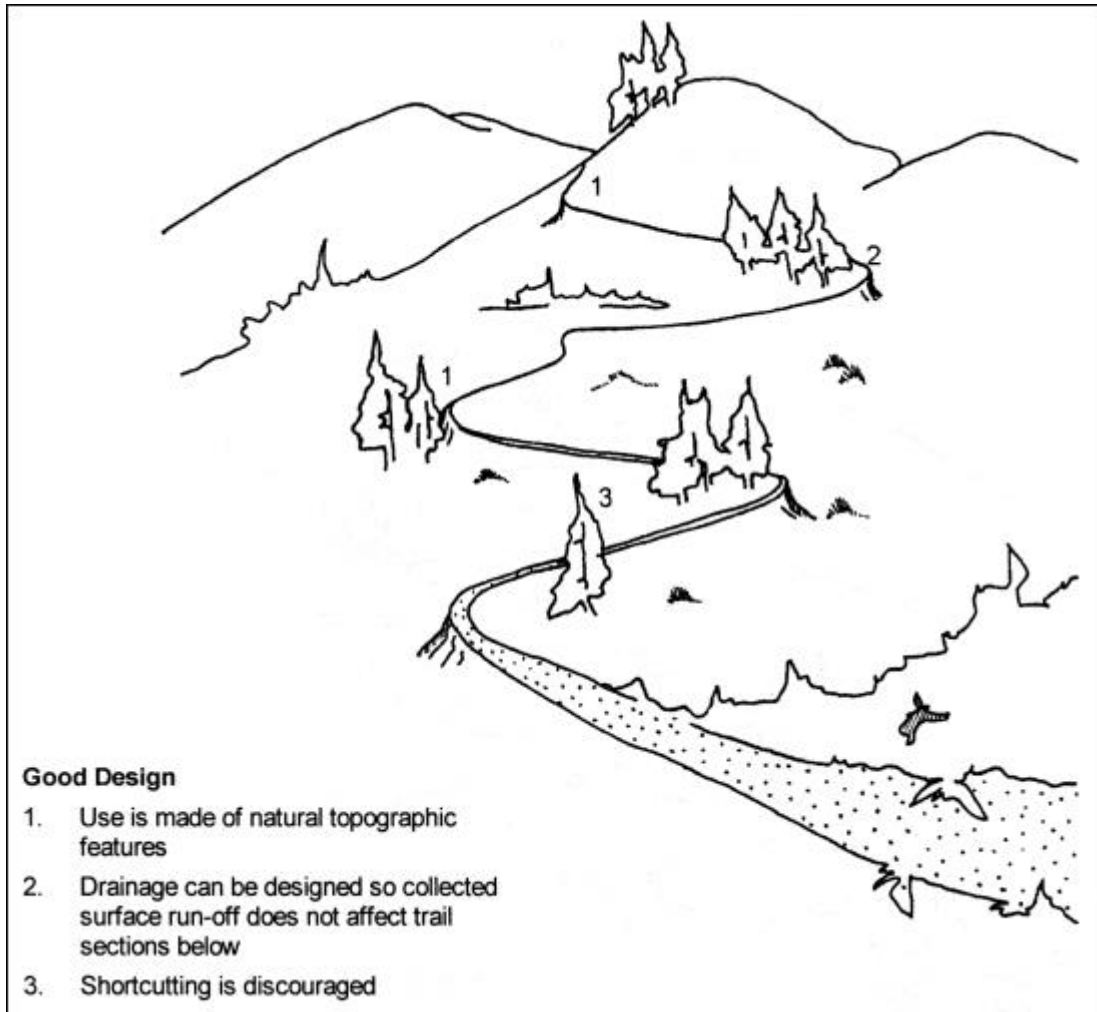
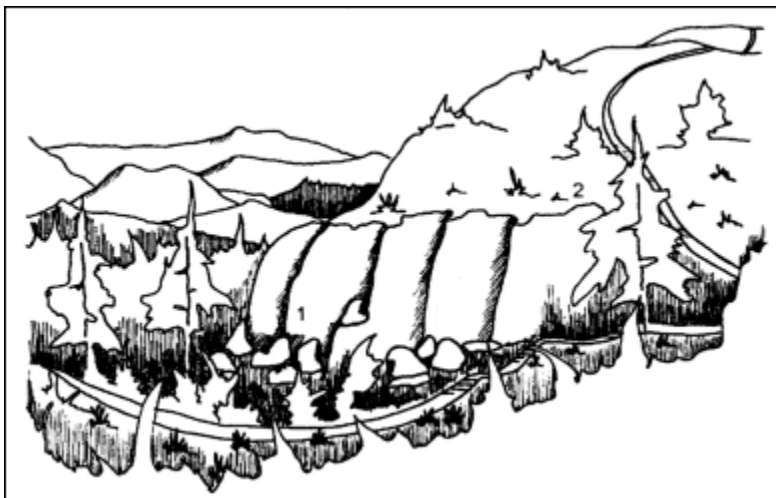

Figure 9: Taking advantage of topography



10.3.5 Guidelines for Specific Trail Classes

The BC Forest Service develops and maintains recreation trails according to the particular experience being provided for the user.

In 1997, the Forest Service adopted the trail classification system being used by BC Parks at the time. This offered several advantages:

- consistent standards and classifications across the province can lead to better cost estimates and maintenance plans;
- trail crews (often employed under contract) could become familiar with trail requirements anywhere in the province, whether in provincial forests or in Provincial Parks. Anticipated results include greater efficiencies and more consistent workmanship; and
- users can gain a better understanding of the kind of experience they could expect, based on the trail type.

Compatibility of use

If trails are to have more than one use, then the trail conditions must meet the requirements of all the expected uses. The compatibility of multiple-use trails must be considered:

- in most cases, motorized and non-motorized use on the same trail is not recommended;
- depending on the volume and season of use, hiking and equestrian use on the same trail may not be compatible;
- bicycle use on interpretive trails or heavily used hiking trails should also be avoided; and
- given favourable terrain conditions and features, many trails may be used in both summer and winter seasons.

TRAIL CLASSIFICATION

Trails are classified according to the recreation activity they will be used for:

Activities

Non-motorized

Foot

Horse

Bicycle

Ski

Interpretive

Barrier Free

Motorized

Snowmobile

Motorbike

All Terrain Vehicle

Four Wheel Drive

Trail Types

The trail standard types range from Type I to Type V:

- type I trails have the highest standards, allowing for the maximum number of users. They have the highest construction and maintenance costs, and will likely have the highest environmental impact; and
- types III, IV, or V have the lowest standard and allow for the least number of users. Construction costs are lower and they are likely to have the lowest environmental impact.

Non-motorized Trail Type Summary

The following guidelines describe the standards used by the BC Forest Service for trail types I to V for non-motorized users, and for level-of-difficulty for motorized users.

ROS Class	Type I	Type II	Type III	Type IV	Type V
Rural					
Roaded					
Semi-primitive					
Primitive					

Standard	Type I	Type II	Type III	Type IV	Type V
Highest standard	—————→				Lowest
Maximum users	—————→				Least
Highest impact	—————→				Lowest
Highest cost	—————→				Lowest
Highest maintenance	—————→				Lowest

Trail Activity	Type I	Type II	Type III	Type IV	Type V
Hiking	✓	✓	✓	✓	✓
Bicycle	✗	✓	✓	✓	✓
Equestrian	✗	✓	✓	✗	✗
XC Ski	✗	✓	✓	✗	✗
Ski Touring	✗	✗	✗	✓	✓
Special Use	✓	✓	✗	✗	✗

✓ Usually provided by Forest Service

✗ Not usually provided

Foot Trails

Foot trails generally require less development than other types of trails and offer the user a closer association with the natural environment. If uses other than hiking are to occur, then the requirements for the alternate uses must also be accommodated.

Foot Trail Guidelines

Foot Trail Guidelines

Trail Types	Uses	Tread Width	Grade
Type I	<ul style="list-style-type: none">• High standard, short walks• 5-30 minute duration• Steady two-way traffic	2.0 m	<= 8% Average <= 5%
Type II	<ul style="list-style-type: none">• Walking trails• Minutes to 2 hours duration• 1 - 6 km	1.25 m	<= 10% Average 5 - 8 %
Type III	<ul style="list-style-type: none">• Single file, hiking trails• 1-7 hour day use, overnight and multi-day• 3-20 km or more	0.75 m	<= 10-12%
Type IV	<ul style="list-style-type: none">• Backcountry hiking trails• Multi-day• Light use	0.50 m	N/A
Type V	<ul style="list-style-type: none">• Backcountry routes over difficult terrain• Overnight to multi-day	N/A	N/A

Type I Foot Trails

Type I trails are typically used in day-use areas, to access vistas and viewpoints located a short distance from vehicle access, and in the vicinity of campgrounds. The high-use nature of these locations usually requires structures, such as toilets. They may also be used as ski trails in winter if the criteria for those trails are met.

Type II Foot Trails

Type II trails are commonly used in conjunction with day-use areas, viewpoints, campgrounds, interpretive areas, or as access to back country trails. Many such trails serve dual functions in that they access specific points of interest that may have moderately high use, and provide access

to back country trails that have much lower levels of use. Type II trails may also be used as ski touring trails in winter if the appropriate criteria are met.

Type III Foot Trails

While Type I and Type II trails best fit the category of walking trails, Type III trails serve as hiking trails, for people travelling single file. Type III trail lengths may be 3-20 km or more. Support structures, such as developed campsites and pit toilets, may also be appropriate depending on the length and use of the trail.

Type IV Foot Trails

Type IV trails are planned as lightly used wilderness hiking trails, for overnight or multi-day duration. Tread widths are only 0.50 metres, and grades are constructed as appropriate to the terrain being accessed. Type IV trails would not normally have support structures, such as developed campsites, but may have pit toilets as required.

Type V Foot Trails

Type V trails are usually wilderness hiking *routes* and specific trail development is avoided. Wilderness hiking routes are typically used for overnight or multi-day trips, and may cross very difficult terrain. Signing, campsites, or other structures are not generally developed, although restrictions may be imposed on camping locations for environmental reasons.

Trail Design Considerations

The length and layout of foot trails is an important consideration, and should be consistent with the type of use the trail will receive.

The width of necessary clearing and trail tread should match the trail type. Type I trails are the widest, with surfaced treads and Type IV trails are the narrowest with no special tread surface treatment. The clearing width may need to be modified if trails are used as ski touring routes.

Trail structures are designed in accordance with trail types and usage level. Type I trails may need engineered bridges, while Type IV trails may not use bridges at all or use simple two-log crossings.

Suitable campsites and waste facilities should be constructed on Type III trails, while Type IV trails have minimum structure development. Any type of development should be entirely avoided on Type V routes.

Bicycle Trails

Bicycle trails may include both mountain bicycle and road bicycle routes. Casual cyclists have different needs from those pursuing the activity as a challenging recreational sport.

Trails that were previously used only by hikers or horses, are now in demand by mountain bikers. This has led to impacts on other users, the environment, and trail maintenance. Appropriate trail planning and maintenance principles help manage the effects of mountain biking. Trail types for bicycles include both mountain and road bicycles, with Types III and IV suited for mountain bike use only.

Bicycle Trail Guidelines

Trail Types	Uses	Tread Width	Grade
Type I	<ul style="list-style-type: none"> • Two-way traffic • Smooth all weather riding • Road and mountain bikes 	2.5 m	Average 5-8% Max. 10%
Type II	<ul style="list-style-type: none"> • Two-way traffic • One-way traffic • Road and mountain bikes 	2.0 m	Max. 10-15%
Type III	<ul style="list-style-type: none"> • One-way traffic, easy to difficult • Mountain bikes 10-20 km 	0.5-0.7 m	Easy: 10% over 30m Difficult: 22% over 45 m
Type IV	<ul style="list-style-type: none"> • Mountain bikes • Difficult • One-way traffic • 30-80 km 	0.3-0.5 m	Sustained 15% 25% over 90 m

Type I Bicycle Trails

Type I bicycle trails are typically two-way bicycle paths for smooth, all-weather riding, surfaced with asphalt or chip seal mixes. They are designed for both road and mountain bikes, and are suitable for all types of users. Type I trails may also serve as groomed cross-country ski trails if the appropriate criteria are met.

Type II Bicycle Trails

Type II trails are also surfaced two-way bicycle paths, but with narrower widths, steeper grades, and compacted gravel surfaces rather than pavement. Existing old road or railway beds may also be used. Type II trails are suitable for both road or mountain bikes, and suitable for most users.

Type III Bicycle Trails

Type III trails are accessible only to mountain bicycles, and are generally unsurfaced one-way trails. Trail obstacles up to 10 cm high may remain if appropriate. Type III trails may be suitable for ski touring in the winter season.

Type IV Bicycle Trails

Type IV trails are accessible only to mountain bicycles, and are generally unsurfaced, longer, steeper and more difficult than Type III trails. Trail obstacles up to 10 cm high may remain if appropriate. Type IV trails may also be suitable for ski touring in the winter season.

Width

A bicycle's handlebars are approximately 60 cm wide and 75 - 100 cm above the ground. The elbows of a cyclist may extend beyond the width of the handlebars. For this reason, a 3 metre right-of-way clearing width is used for two-way surfaced bicycle trails.

A minimum of 2 m cleared width for one-way bicycle trails is used in day-use areas or campgrounds, and a clearing width of 1 - 2 metres is used for the more challenging Type III and IV trails.

Height

A clearing height of 3.5 metres is used on all types of bicycle trails.

Layout and Alignment

Where cycle traffic is to share a right-of-way with automobiles and other motorized vehicles, pavement markings should be used to show boundaries for both cyclists and motorists.

Long-distance trails may incorporate minor or unused roads, easements along highways, power lines, railways and abandoned railway grades.

Curvilinear alignments with varying types of curves create a more interesting trail and may help to avoid cutting large trees. Sharp curves should be avoided at the bottom of long or steep slopes to prevent cyclists losing control. Straight "run out" sections prior to sharp curves help to reduce speed. Visibility on slopes should be clear to reduce chances of collision.

Structures

Bridges

Bridges should have non-skid surfaces. Junctions between the trail surfaces and the bridge should be level. Bridges with railings should be 60 cm wider than the trail tread to allow for the overhang of handlebars. In heavy use areas, an extra 60 cm will allow cyclists to stop on bridges without blocking traffic. Bridges without railings should have wheel stops installed. Wheel stops should be a maximum 15 cm to avoid hitting bike pedals. Bridges should not be located at the end of long or steep grades.

Steps

Steps should be considered for heavy use bicycle trails where grades exceed 10%. Narrow paths or ramps should be built on either side of the steps for users to wheel their bicycles as they walk up or down. Landings should be provided on long climbs. Use of steps requires adequate warning signs and clear visibility, especially from the top approach.

Horse Trails

Horse trails may consist of day-use bridle paths or long-distance routes used by pack and saddle stock. Trails must be designed to consider the environment and the safety of both the rider and the horses. Access to drinking water should be provided at least every 15 km.

Horse Trail Guidelines

Trail Types	Uses	Tread Width	Grade
Type I	<ul style="list-style-type: none"> • Day use only • 1-15 km 	0.5-1.5 m: depending on conditions	Average 0-10% Max. 15%
Type II	<ul style="list-style-type: none"> • Day use or overnight • 5-30 km 	Same as above	Same as above
Type III	<ul style="list-style-type: none"> • Low use • 30-50 km • Multi-day 	Same as above	Same as above

Type I Horse Trails

Type I horse trails should be considered as high-use trails, particularly near campgrounds, major trail heads, or other intensive recreation areas. They may provide for short exploratory rides, and are designed to accommodate a steady flow of two-way horse traffic during peak use periods.

Type I horse trails are generally intended for day-use only. They utilize a gentle uniform gradient and a well-compacted surface, with crushed gravel or stone surfacing unless local soils are suitable for high-use levels and are well-drained.

Type II Horse Trails

Type II trails may constitute trunk components of more extensive trail systems. Existing soils are used for trail surfacing, except where surfacing is required to cross wet or fine-textured soil areas. Type II trails are not normally designed to accommodate winter use, except as snowmobile routes.

Type III Horse Trails

Type III horse trails are intended for low use, multi-day duration trips. Beyond their trunk components, they are generally constructed to low standards and may access wilderness zones.

Length

Type I, day-use trails commonly range from 5 to 15 km depending on the terrain and user ability. Additional loop or spur trails may increase the distance and provide a range of terrain conditions. Long-distance Type III trails may cover several hundred kilometres. Campsite intervals may range from 16 to 25 km.

Right-of-way Clearing

Vegetation should be cleared to a height of 3 m above the tread surface, and the minimum width clearance should be 2.5 metres.

Tread Surfacing

The surface of horse trails should be fairly even, and rocks or roots that cannot be covered should be removed. Additional surfacing materials will be required in areas of sensitive soils or intensive use. Wood shreds are more suitable than chips. Gravel or crushed stone mixed with the existing soils is also suitable. On intensely used bridle paths in rural settings, crushed stone provides the best surface material.

Structures

Fords are preferable to bridges for stream crossing, provided the velocity and depth of the water is acceptable during the normal use seasons. Water depths of not more than 60 cm are safest. Trails should be routed to cross acceptable natural fords. Ford construction requires a minimum 1 metre wide base from which large rocks have been removed and the stream bottom levelled to make a relatively smooth crossing.

If bridges are used over streams or wet areas, they must be able to support the maximum number of loaded horses that may occupy the bridge at one time. Footing should be secure, and if logs are used, they should be flattened on the top. Each log must be secured so that it does not move.

Culverts should be covered with a thick layer of surfacing so that hollow sounds are not made when horses are crossing. Corduroy should also be covered with soil or surfacing material to create an even tread.

On steep side slopes, rocks or logs may be placed along the outer edge of the tread to prevent sloughing of the trail edge.

Additional Considerations

Horses can cause severe damage to trails in wet areas. Once a trail becomes muddy, further damage occurs as horses detour to the sides of the trail. When possible, routes should be located in areas of stable soils. Trails on side slopes require adequate drainage. Trails in wet areas should be re-routed, bridged or filled.

Plant distribution and succession along trails and in grazing areas is disturbed by browsing and trampling. Imported feeds cause foreign plant species to be introduced. Grazing along trails and at campsites should be avoided. Corrals should be provided at campsites and feed should be packed in.

The volume of horse use should be monitored so as not to exceed the carrying capacity of the trail. Access to sensitive areas should be prohibited to horse traffic. If foot trails provide access for riders, tethering places should be available at the entrance to the foot trail. Trails may be closed to horse traffic during spring runoff, after heavy rains or when maintenance is required.

For detailed information on overnight camping, day-use and trailhead facilities associated with horse trails, see [Chapter 9](#).

Ski Trails

The category of "ski trails" includes ski touring, cross-country skiing, and racing trails. Guidelines for ski trails are extensive because climate, exposure, safety and maintenance factors must be considered. The *Cross Country Ski Trail and Facility Development: Construction and Maintenance Manual* prepared by Cross Country B.C. is an excellent source of information and should be consulted in addition to the information outlined in this section.

Ski trail design has evolved into a sophisticated art in recent years, with the increasing popularity of cross-country skiing. Trail planning, design, construction, and maintenance requirements differ from hiking and other summer use trails, although some trail types are suitable for all-season use.

The four trail types within the category of "Ski Trails" may *each* be divided into *Easiest*, *More Difficult* and *Most Difficult* (or Novice, Intermediate and Expert).

Ski Trail Guidelines

Trail Types	Uses	Tread Width	Grade
Type I	<ul style="list-style-type: none"> Suitable for cross-country racing Easiest 3-5 km 	<ul style="list-style-type: none"> Double track Groomed Wide curves 	See section on grades below
Type II	<ul style="list-style-type: none"> Day use More difficult 5-20 km 	<ul style="list-style-type: none"> Double or single track May be groomed Sharper curves 	See section on grades below
Type III	<ul style="list-style-type: none"> Day use or overnight 	<ul style="list-style-type: none"> Single track Not groomed 	See section on grades below

- | | | | |
|---------|--------------------------------------------------------------------------------------------------------|---------------------------------------------------------------------------|-----------------------------|
| | <ul style="list-style-type: none"> • May use existing hiking trail where suitable | <ul style="list-style-type: none"> • Sharp curves | |
| Type IV | <ul style="list-style-type: none"> • Ski-touring route • Often undefined route | <ul style="list-style-type: none"> • Wilderness conditions | See section on grades below |

Type I: High Standard Ski Trail

Type I cross-country ski trails include those short and easy trails with good access that receive high use from all levels of skiers. As an optimum, grooming would be done after each major snow fall and a variety of routes would be provided with different distances.

In areas with high public support and adequate funding, these trails may be built to cross-country ski racing standards.

Cross-country Ski Racing Trail

Cross-country ski racing trails should conform to *Cross Country Canada (CCC)* regulations on length, grade and width specifications. As indicated, trails may be graded as *Easiest, More Difficult* and *Most Difficult* depending on terrain and trail topography.

Type II: Cross-Country Skiing Trail

Type II trails are developed for day-use skiing. They should conform to minimum widths and grades. Optimally, a variety of routes would be provided with different degrees of difficulty and distances, so that a variety of skiing levels and abilities can enjoy the trail system.

Type III: Packed Ski Trail

Type III ski trails are developed for cross-country skiing on a day-use or overnight basis. They are designed and intended for moderate to light use, usually on a one-way loop. Existing summer hiking trails where grades, trail width, and elevation gain or loss is reasonable may be suited for this purpose. Cross-country ski trails are generally not groomed or track-set, but rely on skiers to set tracks.

Type IV: Ski Touring Route

The wilderness skier is a route finder, often using map and compass and not following specific trails. Ski touring routes consist generally of a system of routes over an area undefined by trail markings or grooming.

Climate and Exposure

Trails should be located in areas where snow cover is consistent for several months. A snow depth of 60 cm will adequately cover rocks and logs. Steep, open, south-facing aspects are the first to lose their snow. Open north-facing aspects are more exposed to prevailing winds. Trail location should consider the lee side of hills, wind-sheltered valleys and tree shelter for skier comfort and to reduce drifting and wind-packing.

Length

The total trail length will depend on the number of loops within the trail system. The length of the loops is determined by full or partial day-use and by the ability of the skier. Parks Canada defines the following skier categories:

- slow tourer 4 - 5 km/h
- average tourer 5 - 6.5 km/h
- fast tourer 8 - 9.5 km/h
- racers 9.5 - 13 km/h

Overnight trails should provide accommodation at intervals that can be readily travelled in one day. The lengths of these intervals will depend on terrain conditions and skier ability. For average tourers, intervals of 15 to 20 km may be used.

Grades

Grades on ski trails are one of the factors used to categorize trails into the various levels of difficulty. The three categories of trails include:

Easiest: The maximum grade on downhill runs should not exceed 10%. Slope surfaces should be smooth and curves wide and gentle. Several short slopes are preferable to fewer long slopes because speeds do not become too great and climbing is easier. Descents with steep side-slopes are difficult for novice skiers and should be avoided.

More Difficult: Maximum grades for downhill slopes should not exceed 25%. Curves may be sharp, but ample room should be available for skiers who overshoot them. Downhill sections should not be long enough to let skiers accelerate beyond controllable speed. Up to one-third of the trail may be uphill with some steep but short climbs.

Most Difficult: Maximum downhill grades should not exceed 40%. More curves and rougher surfaces are acceptable. However, long runs on such sections should have more gentle grades. Adequate run-out distance should be provided at the bottom of steep or long slopes. Up to one-half of the trail may be uphill.

On all trails where curves occur on long slopes, the preceding sections should be levelled out or run slightly uphill to allow skiers to reduce speed. Sharp curves should be tilted to the inside. Intersections with other trails or roads should not occur at the bottom of downhill runs.

Right-of-way clearing

Clearing widths for single-lane trails range from 1.5 to 2.5 metres, with the narrower width being used on minor trails only. Two tracks require 3 to 4 metres. Three tracks require 5 metres or more.

Sufficient clearance should be allowed on slopes so that skiers can herring bone or side-step up. This will also provide some safety if skiers fall and will provide room for uphill skiers to step out of the way of downhill skiers. On slopes exceeding 10%, a 3 metre minimum width is recommended.

The clearing height should be 2.5 metres plus the expected maximum snow depth.

Structures and Facilities

Bridges installed on cross-country ski trails increase the season of use. Small streams that freeze solid may not require bridging. Bridge design should be wide enough for tracks and poles, and should be strong enough to support grooming equipment, if necessary. If bridges are high, railings will be required. Engineered bridges may be needed for long spans.

Cabins and Shelters

Cabins may be considered on cross-country ski trails to provide shelter from the weather. Shelters and toilets should be located at main trail junctions or other areas where they can be used by the maximum number of people.

Signing and Safety Considerations

Signing is an important safety factor in cross-country ski trails. All trails should be signed according to the internationally recognized signs and symbols for cross-country ski trails. For information on cross-country ski trail signs, consult the *Cross-Country Ski Trails and Facility Development: Construction and Maintenance Manual*, Cross Country B.C. and [Appendix 6](#) of this manual.

All trails should be marked at trailheads and junctions to indicate the difficulty level. Trails should also be identified along their routes by names or marker symbols so that skiers do not become lost. Information on trail lengths, layout and cabin/structure locations should be available at the trailhead. Trail markers must be designed to be visible in poor weather and must be placed where they will not be buried by snow.

Safety considerations

Trail locations should avoid avalanche areas and hazardous lake and stream crossings. A minimum of 15 cm hard blue ice is necessary for safe crossing on lakes or streams. Trail location should also avoid dense tree canopies, particularly in tall, old-growth stands. The canopy intercepts much of the snowfall and when temperatures rise, large chunks of snow, ice and possibly branches may fall onto the trail.

Snowshoe Trails

Snowshoe trails are designed using the same criteria as easy hiking trails (Type I and II) or packed ski trails (Type III). Backcountry hiking trails (Type III) that have moderate grades may be designated as snowshoe routes. Sustained steep grades should be avoided.

Short trail loops, not exceeding 2-3 km, may be provided in day-use areas. Snowshoe routes are not compatible with groomed cross-country ski routes.

Special Use Trails

Special use trails generally include the following:

- multi-use trails;
- interpretive and wildlife viewing trails;
- barrier free trails; and
- portage trails.

Multi-use Trails

Recreation activities on trails change over time. Each type of trail has specific standards, but some of the standards are suitable for different activities at different times of the year. For example, Type I and II cross-country ski trails may be suitable for Type I or II bicycle trails. Problems arise when trail standards and user expectations are not compatible.

Considerations for multi-use trails

General considerations for multi-use trails include:

- potential conflicts may be reduced by providing separate routes in critical areas. In a backcountry environment where a hiking trail is also used as a horse trail, separate campsites may be provided with detour routes for the alternate user. In addition, detour routes around fragile areas or excess adverse grades are appropriate;
- foot/horse or bicycle/foot combinations in hazardous areas, such as cliff edge routes or steep exposed ravines, should be avoided, as should blind curves on multi-use trails. Curves and hazardous sections should be widened;
- avoid hiker/horse trail combinations near hiker water supplies, such as creek crossings or campsites. Ensure horse crossings are well downstream of hiker crossings; and
- avoid joint ski/snowmobile use, as these two are generally incompatible. Where access routes are limited, use is light, and trails are wide, joint use may be made if ski tracks are set

well to one side. Topographic or vegetation buffers between ski and snowmobile trails helps to reduce noise and exhaust fume impact on skiers.

Interpretive and Wildlife Viewing Trails

The purpose of MoF forest interpretation is *to encourage mutual understanding between the Forest Service and the public regarding forest stewardship to enable the Forest Service to act in the public's interests.*

Interpretive trails should be developed according to interpretive planning principles, and only after an interpretive plan has been prepared for an area, and appropriate themes and messages identified (see the *Forest Interpretation Draft Policy* as well as *Developing Your Wildlife Viewing Site*). Use by bicycles, horses or motorized vehicles should be avoided.

Many interpretive trails are located close to populated areas. Since heavy use and a wide range of user ability are expected, trail design standards must be high in terms of ease, comfort and safety of use. Some interpretive trails may be considered for special needs users and will require wheelchair access.

Location

Interpretive trails may be offered in a wide range and scale of forest settings, from the interpretation of the small pond environment to the interpretation of clearcut logging.

The most interesting interpretive information describes the relationships between the various environmental, cultural and social elements, rather than merely identifying them.

Layout

The most successful trails are designed with a theme focus that allows users frequent stopping space to absorb the interpretive information. The quality of the trail experience depends on how skilfully the route is arranged to provide this sequence of viewing positions.

Loop forms are the most suitable, with spurs and satellite loops providing additional variety. Trail sections with curves and twists increase visitor curiosity and interest, and provide more surprises than long straight sections.

Grades

The most desirable grades for interpretive trails are less than 5%. Sustained grades more than 10% should be avoided, with a maximum grade for short pitches of no more than 15% for a 30 metre maximum. Where wheelchair access is planned, trail grades should not exceed 5%.

Surface and Width

Tread surface and width should be consistent with the terrain and type of use. 1 to 2 metres is a standard width for interpretive trails. Trails are usually widened at signed locations or separate viewing areas. Trails surfaced with wood chips or wood shreds have little impact on the environment, are quiet to walk on, and have a natural appearance.

Barrier-free Trails

Barrier-free trails, sometimes called *special needs trails* are:

- essentially an adaptation of the standards where access by disabled visitors is planned;
- designed to accommodate users who may be aged, visually impaired, deaf, confined to a wheelchair, requiring crutches or a cane, or who have respiratory ailments;
- generally constructed to the appropriate foot trail standards, but length, grades, structures, and tread surfaces are modified as required; and
- designed and maintained to the highest standards for ease of use, comfort and safety.

Grades

Trail grades of 0 - 3% are preferred, and should not exceed a maximum sustained grade of 5%. Level resting areas approximately 2 metres long should be provided at the end of each length of slope, as well as level areas at all turning points on slopes. Slopes exceeding 5% are considered ramps, and on some interpretive trails should have handrails.

Structures

Where handrails are provided, the top rail should be handy for a person walking (90 cm from the ground), and the lower rail situated for persons in wheelchairs and for children (75 cm from the ground). Rails should be strong enough to support the weight of two or three persons. Handrails help persons in wheelchairs reduce speed coming down slopes.

Maximum grade can be increased to 15% for short distances if two handrails are provided 85 cm apart and 75 cm high. The surface of handrails must be smooth so persons do not scrape their hands (e.g., no projecting bolts or nailheads)

Bridges

Bridges, boardwalks and steps should be wide enough for easy passing and should provide secure footing under wet conditions. The surfaces should be constructed using non-skid material, with the boards laid parallel to the direction of the trail. Parallel decking has fewer cracks and edges and is easier for users with canes or crutches. Steep or long steps should have handrails that extend 60 cm past the top and bottom of steps. If these extensions are horizontal, they will alert blind users to the start and end of steps.

Bridges where wheelchairs are used should have a smooth transition from the trail surface to the bridge surface. Where handrails are not used, edge railings that extend beyond the ends of the

bridge should be installed for wheelchair safety and as a guide for blind people. Consult engineering staff when constructing special needs trails.

Figure 10: Handrails on special needs trails - slopes exceeding 5%

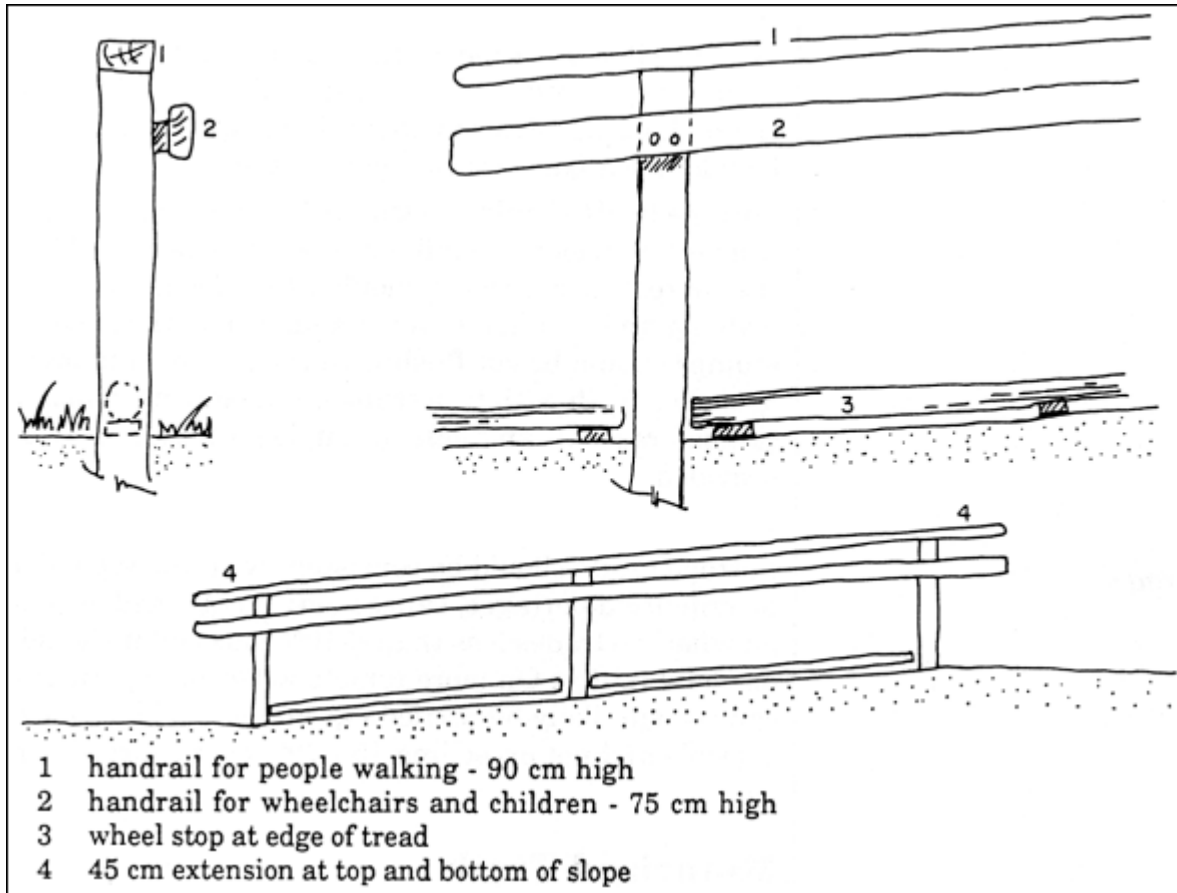

Surface and Width

For wheelchair use on moderately used trails, trails should be 1.2 metres wide for one-way traffic and 2 metres wide for two-way traffic. For minor foot trails, trail widths of 60 - 150 cm are appropriate. For trails where wheelchair use is planned, suitable surfaces should be used, such as asphalt, chip seal asphalt, or boardwalk.

Portage Trails

High-use portage trails should be constructed to Type II foot trail standards, and back country portage trails to Type III or IV foot trail standards. Portage trails should be designed and maintained for ease in carrying or hauling canoes or other craft.

Portage sites must have safe and smooth landings, preferably with sandy or rounded gravel shoreline material, and on rivers, landing sites should not have upstream or downstream boulders, log jams or other obstructions.

Portage trails should be cleared 1.5 metres wide for portaging canoes and wider if small motorboats or rafts will be used on the route. Sharp corners should be avoided; they prevent easy walking and turning with a standard length canoe. All stumps should be cut flush with the ground and protruding branches flush with tree trunks. Canoe rests, where a canoe can be braced at an angle by single portagers may be provided.

Grades

Portage grade should be consistent with the type of use. On heavily used portages, canoes may be dragged over the route on wheels. Grades less than 8-10% maximum should be used on these routes. On more remote wilderness portages, where canoes will likely be carried, grades should be as level as possible and not exceeding 15-20% over short distances.

Motorized Trails

All the guidelines for motorized trails are adapted from the US Forest Service *Trails Management Handbook*. For details on overnight camping, day-use and trailheads associated with motorized trails, see [Chapter 9](#). Refer to [Appendix 2](#) for information on standard FS structures.

ATV trails

Obstacles and frequent short turns should be avoided on novice trails. Wide-radius climbing turns are preferable to switchbacks. Switchbacks on steep slopes should only be used for difficult trails.

Wet sections and small logs may be used as obstacles on intermediate and difficult trails. Shallow, short, wet crossings 15 cm deep may be used occasionally on novice trails.

ATV trails should be restricted to one-way traffic. If two-way traffic is expected, turnouts will be required.

All-Terrain Vehicle Trail Guidelines

Snowmobile Trails

A multiple loop layout is most suitable for day and partial-day use. Due to the speed of snowmobiles, fairly extensive trail systems may be developed from 24 - 180 km.

If snowmobile routes cross highways, roads or railway lines, the crossings must be coordinated with the appropriate agency. Trail crossing and junctions should be at right angles and should be well-signed from both routes. Level grades are necessary on crossing approaches to permit riders better speed control. No more than two trails should intersect at any one junction.

Potential hazards must be carefully evaluated prior to route development. Snow depth, avalanche potential, light conditions, the possibility of night use, and the presence of cliffs, gates, fences or water crossings all affect route selection.

Snowmobile Trail Guidelines

Grades

Variety in vertical alignment adds interest to the trail; however, it must be used in proper combination with horizontal alignment to control speed for user safety. If suitable terrain is not available, the 25% grade limit may be exceeded for short distances provided that:

- approaches to the steep portions are horizontally straight, and have gradual grade transitions; and
- the resulting grades do not compromise safety or the enjoyment related to ease of operation.

Four-wheel Drive Trails

These trails generally utilize existing routes that have been constructed for other purposes, such as mining or timber harvesting. Existing routes considered for four-wheel-drive use should meet the requirements for the particular category of trail required.

The degree of trail difficulty changes according to the size of the vehicle. The intermediate level of difficulty for a short wheel base vehicle will be the maximum level of difficulty for a long wheel base vehicle. Having several tight turns requiring five lock-to-lock turns at the beginning of the trail is one method of controlling the class of vehicle using the trail. The rest of the trail should have less tight turns. Two-way traffic should be avoided on four-wheel drive trails.

Four-Wheel Drive Trail Guidelines

Motorcycle Trails

Motorcycle trails located in the forest setting may utilize existing roads, but should avoid roads where vehicle licencing is required. Alternate vehicle use on motorcycle trails should be prohibited.

Alignment on easy trails should not combine sharp curves with rough surfaces or steep grades. A loop form of trail layout provides a variety of distances and terrain conditions to the user. Experienced riders may cover 80 to 120 km in an average day.

Climbing turns are preferable to switchbacks. Climbing turns or switchbacks in areas of sensitive soils will require trail hardening. Concrete blocks secured with a rebar anchor may be used for this purpose.

Bridges should have a straight-on approach and should be constructed with a minimum 1 metre clearing. Trail junctions should be clearly visible from both routes, and no more than two trails should intersect at any one junction.

[Motorcycle Trail Guidelines](#)

[[Top](#)]

10.3.6 Final Design Plan

The final trail design plan translates the concept plan and trail evaluation information into final drawings, construction methods and specifications, cost estimates, and scheduling procedures.

The production of a trail design plan is necessary in order to:

- ensure that the concept plan has been accurately translated into the trail proposal;
- provide a means of communicating what is required to the construction supervisor, Forest Service personnel and public user groups;
- facilitate the final approval of the project; and
- provide a record of the trail development for future operations and maintenance needs.

Final location of the trail should be traversed (preferably using a GPS) to determine the location for referral, clearance and establishment. Construction should not proceed until the trail has been properly established or approved (*Forest Practices Code Act*, Sec. 7 and Sec. 102).

Trail Drawings

The final location of the trail should be shown on the prepared base map of the trail area. Specific recreation and landscape features associated with the trail may be presented on the same map.

The specific location of all the construction requirements, such as bridges, grade dips, right-of-way clearing and switchbacks, should also be shown. The locations of these items may be presented as straight-line diagrams or as log records. They may also be shown on the trail route base map, providing the details can be shown at the base map scale. The following table is an example of a construction log report adapted from the US Forest Service *Trails Management Handbook*.

Construction Log: Barclay Lake Trail

<i>km + m</i>	<i>Work Item</i>	<i>Remarks</i>
00	begin project	
0.40 - 0.80	remove outslope	
1.50	sand and gravel	
2.8 - 3.10	install log rounds	
4.00	grade dip	

Trail drawings should also include a map of the trail route showing any limitations to trail use or carrying capacity considerations. This will facilitate future design or construction changes.

Construction Specifications

Construction specifications should provide all the details of the work required, including

- written descriptions and standard drawings showing dimensions, sizes and configuration of the various construction requirements;
- grade, trail width and right-of-way clearing specifications; and
- estimates of the quantities of each type of trail work. For example, one switchback, 2 m of 30 cm aluminium culvert, seven waterbars, four dangerous trees and snags, and 5 km of clearing. These are essential in developing cost estimates for trail development.

Cost Estimates

Preliminary cost estimates of various trail route alternatives are an important decision-making factor in choosing the final trail location. Structural requirements are costly and are of primary concern in the design phase of trail development.

Final cost estimates reflect construction specifications, quantity estimates of work items, and projected maintenance and operation costs. The *Recreation Cost Breakdown* sheet (FS 912) may be used in the cost estimate procedure (see [Appendix 1](#)). Program planning and budgeting procedures are outlined in [Chapter 4](#).

[[Top](#)]

10.4 Trail Construction

After the trail planning and design process has been completed, and project funds have been allocated, construction or reconstruction of the trail can proceed.

The trail construction phase of development should reflect the same degree of thought and consideration as the planning and design phases. Construction practices must meet the specifications and guidelines of the design package.

Well constructed trails ensure user safety and environmental protection and, ideally, should blend into the surrounding landscape. Depending on the complexity of the terrain and user intensity, it will cost less over the long term to construct and maintain trails that are well designed and well constructed.

Trail construction may be undertaken by Forest Service work crews, volunteer user groups or contract crews. All of these options require supervision of a qualified trail construction coordinator. Good supervision involves coordinating the construction and conducting regular inspections to ensure specifications are followed accurately and to maintain quality control. Log

records, including contract and/or material payments, must be kept up-to-date and maintained throughout the construction process.

Principles

All trail construction involves basic procedures related to staking, trail tread construction, clearing, debris removal and building of required structures.

The trail construction process comprises three main elements:

- preparation for trail construction;
- trail construction procedures; and
- trail drainage.

The last two elements are usually taking place at the same time, but since trail drainage is so critical to building a trail that will last and be easy to maintain, it is given a distinct focus.

[[Top](#)]

10.4.1 Preparation for Trail Construction

Preparation for trail construction is based on:

- existing plans (e.g., sub-regional, LRMPs or district recreation plans);
- a clear understanding of the trail Type (I-IV); and
- whether materials are supplied or to be found on site.

Type I and II trails will be in front country and high-use areas where aesthetics and user impacts require the use of prepared building materials, such as dimensional lumber and gravel, and the likely use of machinery.

Type III and IV trails generally have lower levels of use and attracts more experienced users in a back country setting and, therefore, they:

- have an aesthetic value associated with natural materials;
- need trail crews able to make on-site decisions about construction techniques and use of on-site materials; and
- need to blend into the natural setting, except where required for safety or structural integrity.

Specifying Construction Techniques

Trail crews working in back country areas should:

- avoid overbuilding;

- seek to minimize changes to the existing conditions;
- use design details that are simple, functional and complement the natural setting;
- try to avoid stairs and steps built into the trail tread (creates high maintenance commitments, can be difficult to negotiate, and can cause erosion problems);
- use low-level bridges in wilderness zones without handrails; and
- make natural trail markers and signs.

Design and construction details contribute significantly to the cost and effort required for long-term maintenance and as a general rule:

- drainage dips require less maintenance than culverts; land
- the cost of routing trails around areas that would require significant structures may be recovered through maintenance savings.

Safety

It is important to conduct a job/project safety analysis prior to starting trail construction. Part of the construction planning process includes consideration of:

- regulations and policies regarding personal protective equipment;
- equipment operation safety; and
- regulations pertaining to first-aid equipment and attendants (usually based on number of workers and distance from medical facilities).

Standard safety requirements must be adhered to. For both safety and efficiency, it is often most effective for people to:

- work in small groups; and
- spread out along the marked route.

If everyone works in the same spot, the increased greater congestion can lead to lower efficiency and, more importantly, a far higher risk of injury.

Selecting Construction Materials

Construction materials used for trails are selected on the basis of:

- cost, availability, ease of use, appearance, strength and durability;
- trail type; and
- transportation of materials to the site, minimizing damage to the trail, and maximizing quality of construction.

Native materials, usually wood or rock, are either cut or dug near the trail, but out of sight. This is one of the primary criterion when choosing native materials - that they be unnoticed and subtle.

Wood Materials

Trees should be:

- cut to appropriate length, limbed, and peeled uphill and out of sight of the trail; or
- prepared at the trail and debris removed, if peeled logs are too slippery.

Pressure-treated wood may be suitable, if:

- resources for transportation are available (taking into consideration the long-term, increased maintenance costs of untreated wood); and
- not permanently immersed in streams or rivers where toxins can leach into the waters.

Rock Materials

When using rock:

- rock debris not used in trail construction should be removed out of sight of the trail;
- holes left by removal of rock should be filled with dirt, dead brush and other forest litter; and
- avoid cutting bedrock near the trail, so as not to leave a visible scar.

Soil for Fill

When using soil for fill:

- borrow pits can be near the trail, but out of direct view;
- pits should be filled with debris and hidden; and
- it is best to gather materials in several locations to reduce feeder trail damage.

Selecting Trees for Durability

Although choice of tree type may be limited, it is important that the most durable material be selected even when found at a considerable distance from the trail. Some tree species are classed as "naturally durable" as they possess substances produced within the tree that are harmful or toxic to fungi, the organisms responsible for wood decay.

The following chart describes the natural durability and ease of preservation of the most common species in this province.

Species	Natural Durability					Ease of Preservation			
	>25 yrs	>15 yrs	>10 yrs	>5 yrs	<5 yrs	very diff.	Diff.	Mod.	Easy
Alder									
Birch									
Cedar, Red									
Douglas fir									
Balsam fir									
Grand fir									
Hemlock									
Maple									
Lodgepole pine									
Spruce									
Willow									
Yew									

Preventing Decay

The fungi responsible for wood decay require moisture:

- Freshly felled timber can contain as much weight of water as wood substance - 100% moisture content.
- Timber with a moisture content below 20% will not decay.
- Once timber is dried to below 20% moisture content, it will not exceed this level simply by exposure to damp air.
- Timber can be protected from increasing its moisture content by the application of water resistant coatings, such as exterior stains. Only a high quality coating with a long working life should be considered because regular maintenance of the coating itself can become costly.
- Timber in contact with the ground is most at risk.
- Pressure-treated wood is particularly recommended for use in high traffic areas.

Selecting and Preparing Equipment

Equipment resources for any trail construction or modification project must be assembled prior to starting work.

- Type I and II trails - small size mobile construction equipment, such as bobcats, backhoes, small graders and gravel-spreading or asphalt-paving equipment.
- Type III and IV trails - hand tools and small hand-held power tools are the only equipment that can be effectively transported to the site.

Commonly preferred tools for the following jobs include:

- *Clearing a right-of-way through trees and brush:* bow saws, loppers and hand pruners for small cuts, a chain saw for larger cuts, and long-handled axes for general work including bark peeling.
- *Trail grubbing:* mattocks and picks (sometimes combined as pick mattocks) and rakes for finishing.
- *Rock work:* long pry bars; come-a-longs for moving large rocks or heavy logs.
- *Dirt moving:* long-handled, pointed shovels.
- *Log work:* splitting wedges, sledge hammers and peevees.

[[Top](#)]

10.4.2 Trail Construction Procedures

Staking the Route

Staking the trail route from start to finish is the first basic step in trail construction. Stakes should be placed:

- along the entire route before clearing and construction;
- on both sides of the trail showing differences in trail width (only the centre line needs to be staked for minimum standard trails); and
- to define the trail bed to be cleared or excavated (important on curves).

Some trail sections may require design changes depending on site-specific field conditions.

Only the centre line needs to be staked for minimum standard trails.

Identifying the Drainage Requirements

The three golden rules of trail maintenance are:

- (1) drainage;
- (2) drainage; and
- (3) drainage.

Even the smallest amount of water going the wrong way at the wrong place can, over time, erode an otherwise well built trail.

Ensuring trails are not damaged by rainfall and surface run-off is perhaps the most difficult and expensive component of trail construction and maintenance. Not all drainage problems can be avoided by careful trail routing, and special techniques may be needed to channel surface water and maintain the trail tread.

The best way to prevent drainage problems is to identify problem areas *before* the trail is constructed, and to incorporate drainage requirements into the tread construction. Regardless of

the type of trail, surface water must not be allowed to run along, or collect on, the tread surface for long periods.

For details on constructing drainage, see [Section 10.4.3](#).

Clearing the Route

With care, it should be possible to avoid large or feature trees when routing trails. Do not cut trees unnecessarily.

Figure 11: Clearing the trail

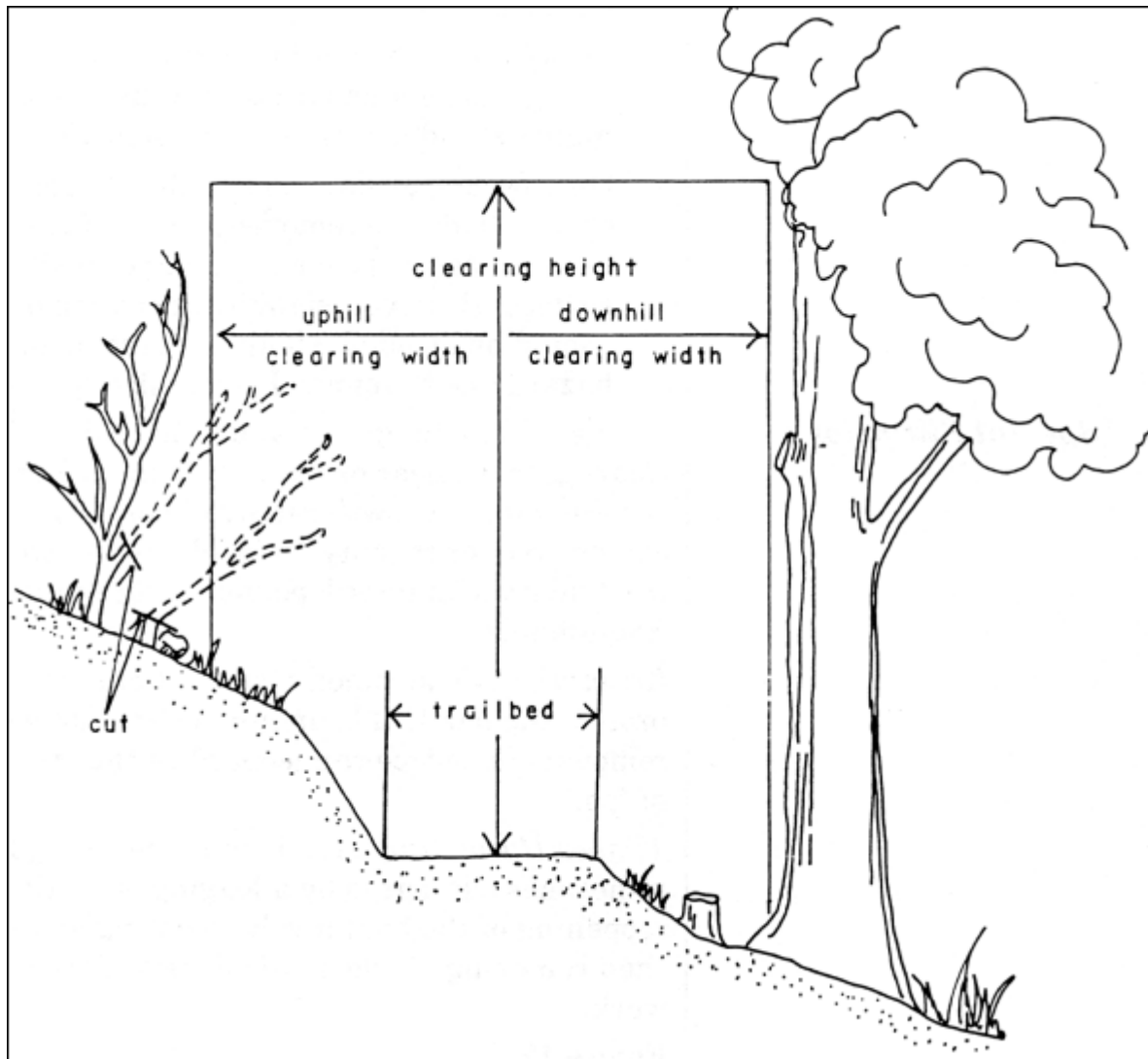

- If a short treetop has to be removed, it is generally better to remove the whole tree, since removal of the terminal bud will aggravate lateral growth into the trail and leave an unsightly tree.
- Cutting all lateral branches on the trail side of a tree is the second best option, better than cutting off the top of the tree.
- Vegetation is cleared to provide safe and unimpaired movement along the trail. Adjacent shrubs and small trees that will quickly grow back into the right-of-way are removed, as are branches that will obstruct travel.
- The clearing limits will vary depending on the use of the trail. Branches are normally cleared to a height of 2.5 metres on hiking and bicycling trails, and higher for winter use or equestrian trails.
- Stumps are cut flush with the ground and branches flush with tree trunks.
- Rocks should be left in place unless they are numerous enough to be a hazard to trail users or, in the case of higher standard trails, to construction equipment.
- On bicycle trails and ski trails, all large rocks and obstructions are removed. Small exposed roots are cut back to the trail edge to prevent growth through the trail surface. However, significant cutting of large tree roots should be avoided where it might result in a windfall hazard due to removal of stabilizing root systems.

Special Situations

Alpine trails - Judgement and temperance should be used when clearing trails near or above treeline, where the climate is severe and the growth rates are very slow. Trees a metre tall can be sixty or seventy-years-old. Small trees and shrubs at treeline grow in interdependent communities called *Krummholz*.

Krummholz. The joined roots and branches of these trees help protect the patch of *krummholz* against wind and cold, so removal of one tree can jeopardize the other trees in the patch.

Timber Harvesting - Trails in the working forest are sometimes cut across by a logging operation. Clean up and reopening of the trail involves locating and flagging the trail, then removing all slash and debris.

Figure 12: Removal of large branches

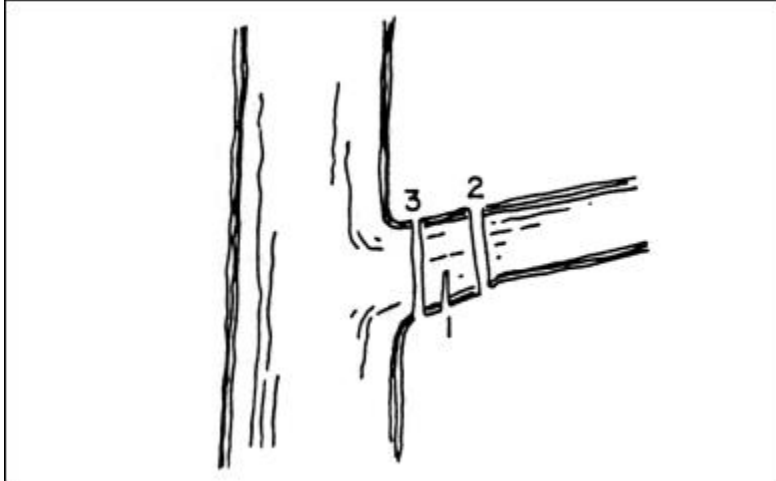

- Large branches should be removed by sawing in three places to prevent tearing the bark.
- Brush over 30 cm high and 1.5 cm in diameter that extends into the clearing limits should be cut flush with the main stem at a branch fork or at ground level.
- Windfall that interferes with the trailbed should be removed or wide sections cut through the trunk. If the tree or snag is too heavy to move, a section that is tread-width plus 30 cm on each side should be cut and removed.
- On sideslope trails, the upper cut should be 30 cm back from the top of the embankment.

Figure 13: Windfall clearing

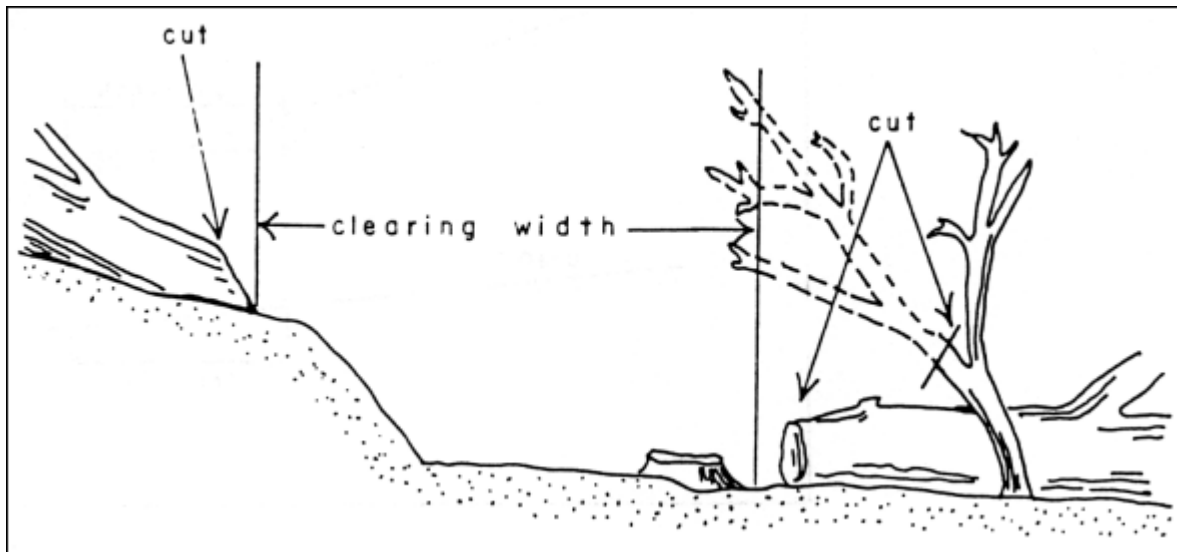

Constructing the Trail Tread

Before full excavation and construction take place, a narrow work path is cleared and excavated from the outside stake toward the centreline. This path establishes the grade and excavation line for the rest of the trail bed. If alterations are needed, less time is wasted and less damage done than if the entire trail had to be graded.

No grading is required on level or nearly level terrain.

Side Slopes

On side slopes, trail bed construction depends on the degree of slope.

Figure 14: Trail bed construction on different sideslope grades

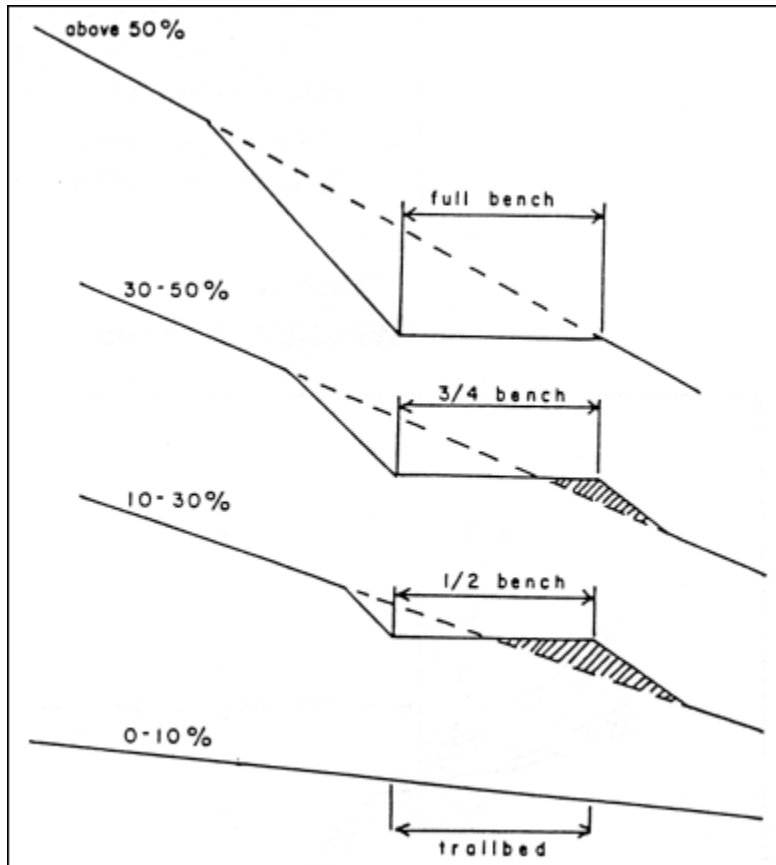

The following considerations apply to trail bed construction on side slopes:

- Leaf litter and surface soil material should be removed from the cut and fill areas, and saved for later use.
- The ideal angle of the cut and fill slopes should be less than a 1:1 slope.
- To encourage vegetation regeneration, topsoil and organic material should be spread on large embankments susceptible to erosion. On steep embankments, netting material, such as jute mesh held in place with stakes, may be required to hold the topsoil and mulch in place.
- Proper rounding at the top of the embankment shoulders is necessary to prevent soil from sliding onto the trail. Boulders, logs and other debris that may fall onto the trail should be removed. Exposed roots should be cleanly trimmed flush with the soil surface.
- The bed of the trail tread should be pitched approximately 1.5 cm per 30 cm toward the outside edge to allow for drainage off the trail.

The following figure shows an ideal trail section with banks and trail surfaces properly sloped and corners of cut and fill embankments properly rounded.

Figure 15: Trailbed construction on a sideslope

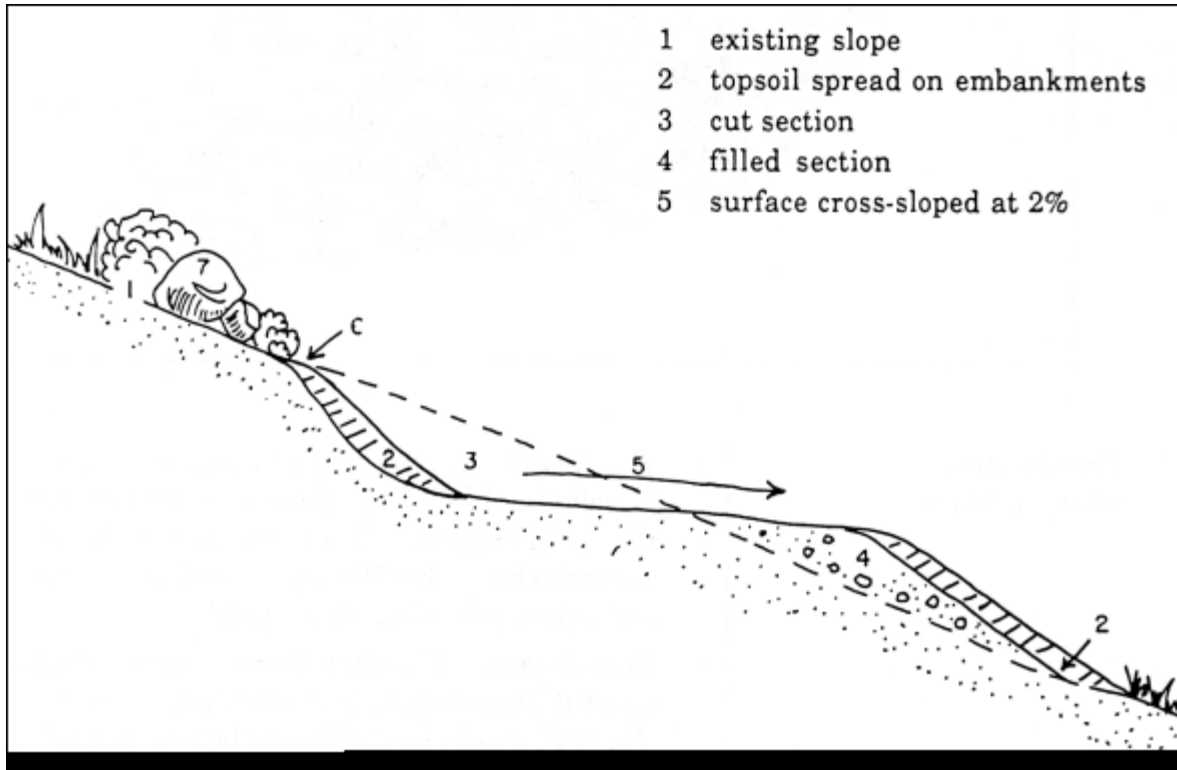

Steep slopes

For narrow wilderness trails on steep slopes, a log may be wedged parallel to the outer edge of the trail against two standing trees. The gap between the log and the slope is filled with small branches, rocks and earth to achieve a shelf for the trail.

On talus or rubble sections where little or no soil is present, the outside trail bench should be made with hand-placed stones, 50% of which are 30 cubic cm or greater.

Figure 16: Trail bench construction in talus and rubble

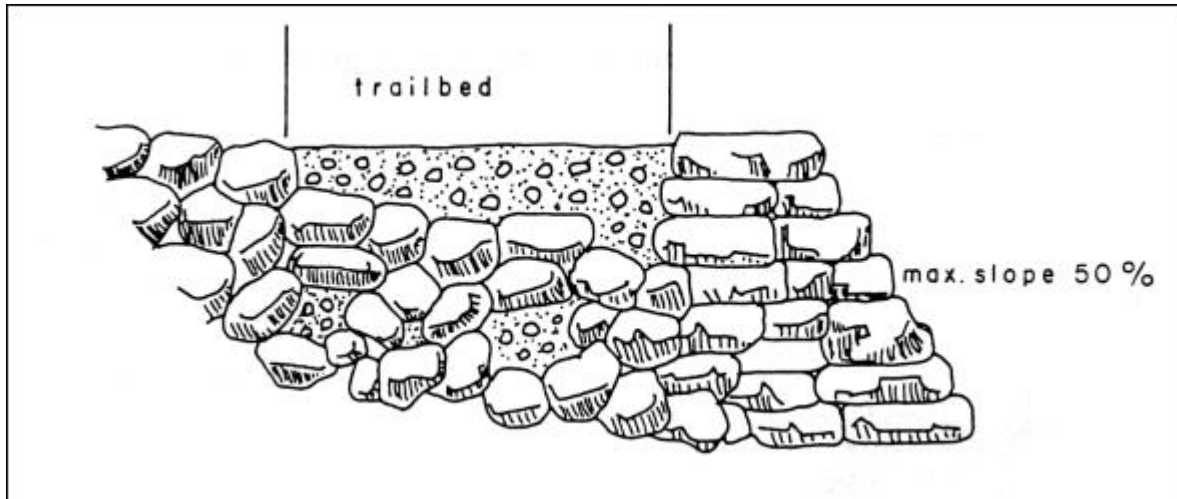

Trail bench construction

- *Trail bench construction in talus and rubble.* The outside bench should be built from rock other than those forming the inside bench. All voids in and under the trail bed surface should be filled with rock and mineral soil deep enough to provide a firm tread.
- *Switchbacks.* Constructing a switchback properly takes careful planning. It is particularly important to steepen the trail grade immediately before and after the turn so that the turn itself has a reduced grade.

Figure 17: Switchback details

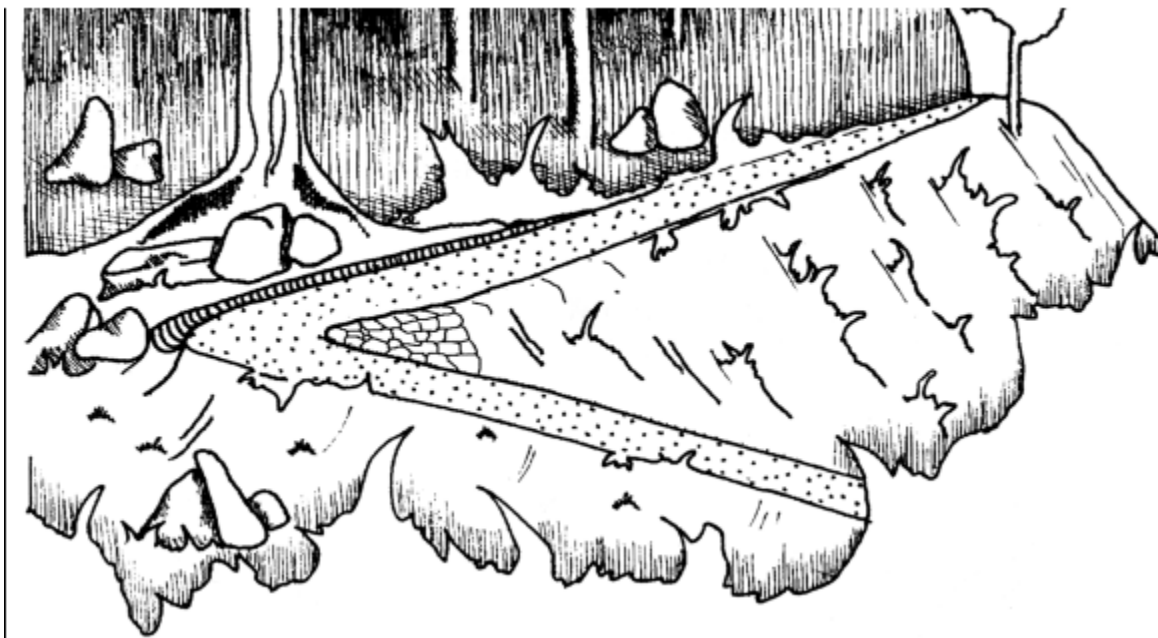

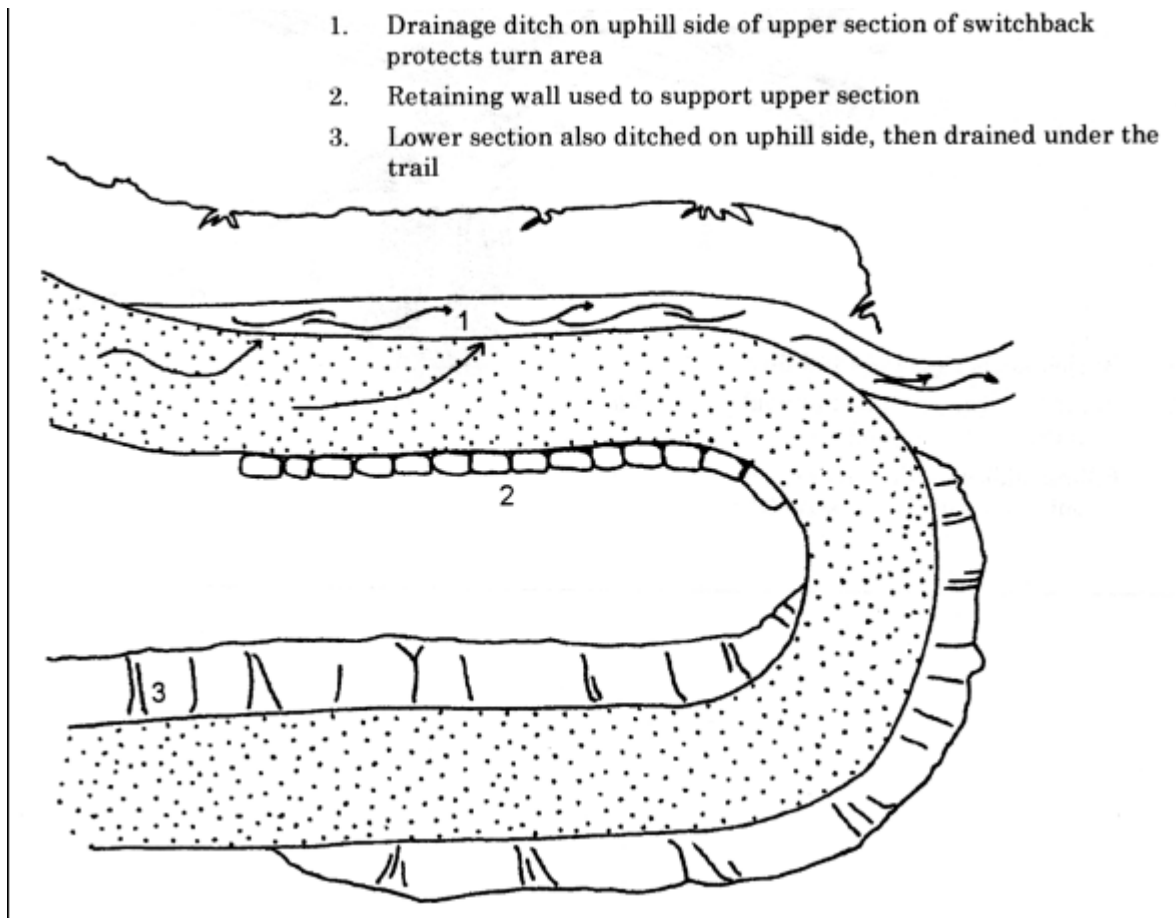

Building Retaining Walls

Retaining walls help retain slopes, prevent erosion, and protect trails and users from falling debris. Retaining walls are usually built from logs and earth. The type of retaining wall constructed usually depends on the strength required and the type of materials available.

The following figures show retaining walls built from three different types of materials: log, timber and dry stone/rubble.

Figure 18: Log retaining wall

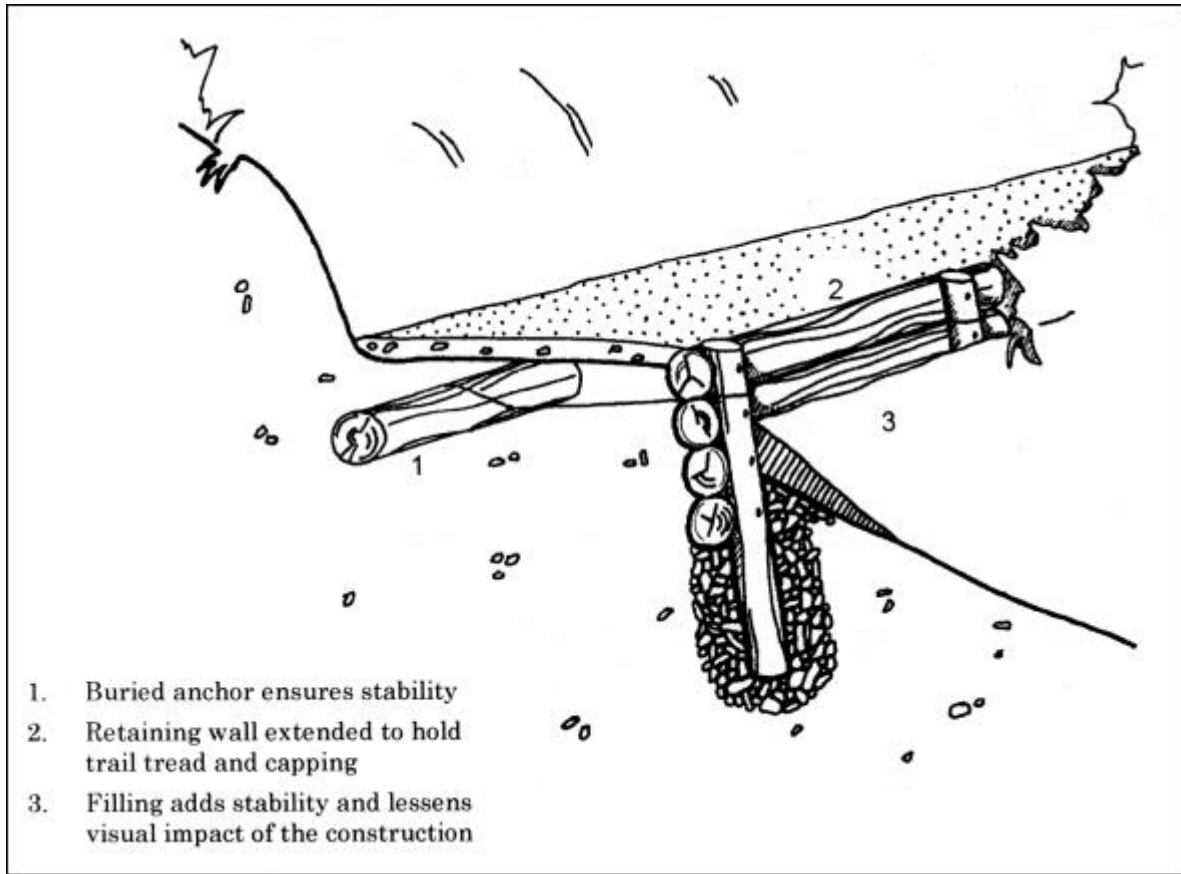

1. Buried cross beams ensure stability
2. Gravel backfill drains water to lessen pressure on retaining wall
3. Timbers lean into slope and are pinned, for stability

Figure 19: Timber retaining wall

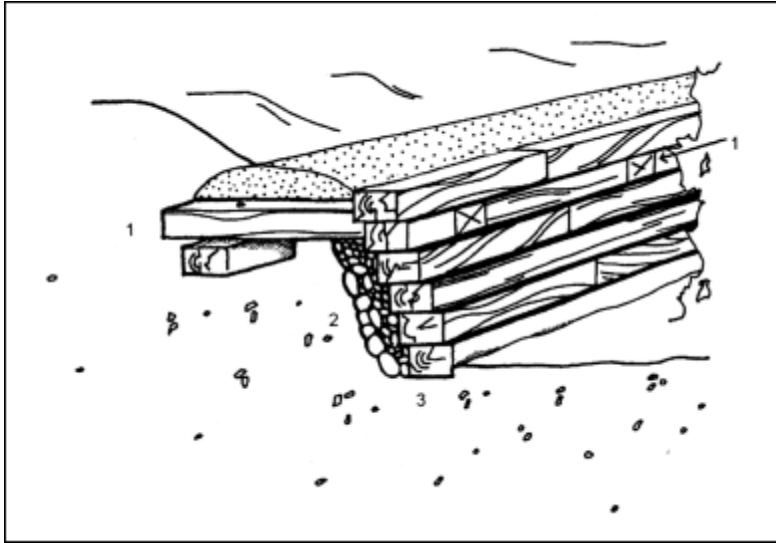

1. Retaining walls are often used to support upper section of a switchback
2. Gravel backfill helps drainage
3. Ditch at base of wall helps protect lower section of trail from run-off

Figure 20: Dry stone retaining wall

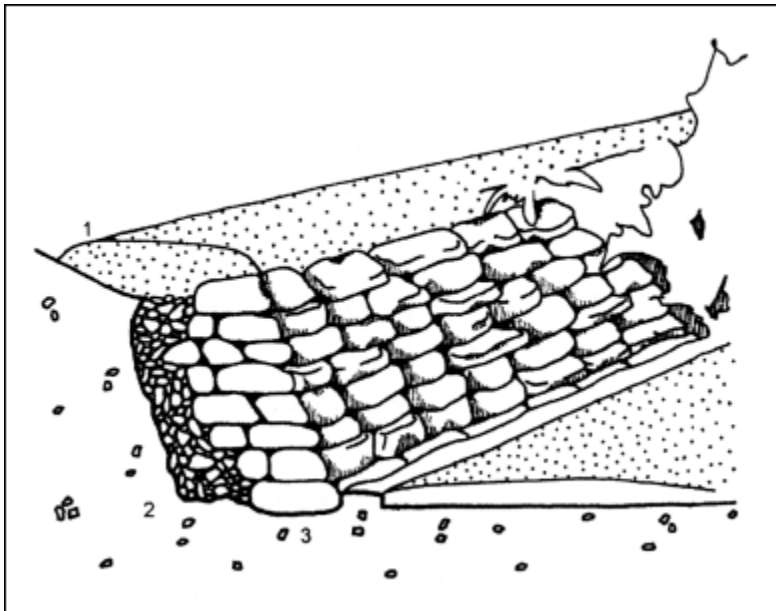

Preparation of the Tread Surface

On level or nearly level areas where soil conditions are suitable for trail use, the leaf litter and surface soil should be left in place.

In situations where surfacing material is required, the leaf litter and surface soil material should be removed from the tread area. This material should be used on the edges of the trail along the embankments to encourage vegetation regeneration.

Roots:

- Small roots should be cut back to the trail edge to prevent sucker growth through the trail surface.
- Large tree roots should not be cut if it would result in windfall.
- Cuts should be made cleanly, flush with or just below the ground surface.

Subsoil should be compacted to provide a firm base for the surfacing. Where compaction of fill materials is not possible, additional material should be applied once natural settling has occurred.

Tread Surfacing

The best tread surface is generally obtained by planning the trail route over the most suitable soils. Requirements for importing surfacing materials can be minimized or eliminated by locating trails on well-drained, coarse-textured soil. **Avoid clay, organic soils or pure sand soils.**

The types of materials used for trail tread surfaces are described below.

Native Soil Materials

An existing cover of native sod will remain intact after light pedestrian use, but heavy use will result in a mineral soil tread. Native sod should be removed only if the soils are coarse.

Some excavation of the trail bed may be required before a new surface is applied if the original surface is made up of fine soil. After excavation, crushed gravel or a similar local material rolled or tamped down to compact can then be applied. Mixing clay or fine limestone with sandy tread soils will bind soil particles and provide a firm walking or riding surface.

Wood and Bark Chips

Wood chips and bark blend in well with natural surroundings and are quite comfortable to walk on. However, wood chips have several disadvantages:

- not usually firm enough for bicycles or special needs trails;
- scatter easily;
- do not compact well;
- may become slippery when wet; and
- not suitable for sloping trails.

Wood and bark shreds:

- require less maintenance and compact better for easier walking; and
- should be suitable for the trail tread, e.g., hemlock, spruce, pine, or fir chips.

Not suitable:

- wood shavings and sawdust for cycling trails or trails intended for wheel chair use; and
- cedar wood chips should never be used because they produce toxic leachate that could poison local streams.

Crushed Stone

Crushed stone or gravel provides:

- a smooth, durable, firm surface suitable for trails with heavy use; and
- easier repairs than asphalt surface, without patches.

Round gravel does not bind well and should not be used for trail surfaces.

Clay/gravel mixtures provide a trail surface similar to asphalt or concrete in consistency, and have the advantage of not spreading out beyond the trail boundaries.

Screened or 'pit-run' gravel (an inexpensive grade of screened gravel) provides a good surface material and is relatively inexpensive if found locally.

For optimum trail surfaces, three-quarter-inch minus or half-inch minus crushed angular stone or gravel, mixed with sand and clay, is best (sometimes referred to as "road gravel").

Crushed Limestone

Crushed limestone is a similar surface to most types of gravel. Limestone is generally rolled to provide a smooth surface suitable for most uses, but must be graded regularly to maintain an even grade.

Asphalt Surfaces

Trails surfaced with asphalt mix over a compacted sub-base are suitable for Type I foot and bicycle trails. Although development costs are high, maintenance costs are much lower than trails with other types of surfaces.

Soil Cement

Soil cement is a mixture of several centimetres of local material, preferably gravel, with cement and water. This type of material produces a hard, durable trail surface, suitable for very heavily used trails. When the surface is crowned, this surface will shed water and is resistant to erosion.

Shale and Granite

Fine, compacted shale is similar, but superior, to compacted gravel when used as a trail tread. Coarse shale is crushed before applying. When this material is used on a crowned trail surface and compacted, it will form a durable surface that sheds water.

Decomposing granite can provide a smooth, compacted finish; however, trail beds using this type of material can become muddy in some areas after a heavy rainfall. Some types of granite are better suited for trails than others. Materials should be tested before they are used for a large project.

Geotextile Barrier

In fine or wet soils, you may find a barrier between the granular surface material and the native mineral soil helpful.

A geotextile (or geofabric) material (also referred to as a soil separation blanket):

- is a non-woven polyester cloth;
- is a semi-permeable membrane used to separate gravel surfacing or fill from the soft soil below;
- allows free movement of water;
- inhibits the downward movement of gravel into boggy soil; and
- allows hard setting gravel to be laid directly over the fabrics on soft clay and even peat soils, if adequate drainage provided.

Geotextiles can be:

- overlain with aggregate and surfaced with fines; and
- set into a shallow excavation (usually 150 mm) and built up with aggregate and fines.

In both of these methods, it is important to anchor the edges of the geotextile to prevent it from shifting and disturbing the firmed-up surface:

1. Raise the sides of the laid geotextile material over a sill.
2. Secure with excavated material. This "wrap" prevents the fill from spreading.

Peat soils must be sufficiently stable (non-springy) to support the gravel surface. Any movement in the peat soil formation will crack the upper gravel seal.

A thick surface layer of well-graded gravel, when laid on geotextile material and provided with adequate drainage, should tend to set firm. Treadways should have waterbars installed to prevent erosion of the fill material.

Geotextiles should only be used on minor to moderate slopes of maximum 10° (17%).

Geotextile barrier

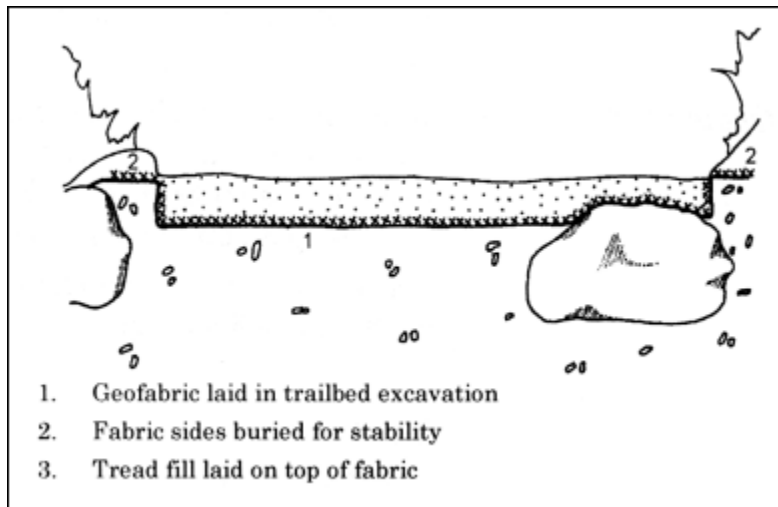

[[Top](#)]

10.4.3 Trail Drainage

Effective drainage is essential to promoting trail safety and stability, and minimizing maintenance costs.

The list below gives examples of some drainage features used to promote drainage on trails. Simple drainage designs are the easiest to apply and maintain. The first five types of drainage on this list are the most frequently used.

- Trail crowns and cross slopes
- Drainage ditches
- Culverts
- Drainage depressions and dips
- Cross drains and waterbars
- Drainage turnpikes
- Switchback drainage

Trail Crown and Cross Slope

Crowning is the sloping of a trail from the centre towards its outside edges in order to promote drainage of surface water. Crowns are suitable over level ground or where drainage ditches exist on both sides of the trail.

Cross sloping (sloping the trail towards the downhill edge) is used where drainage on the uphill side is not practical.

Figure 21: Trail crown

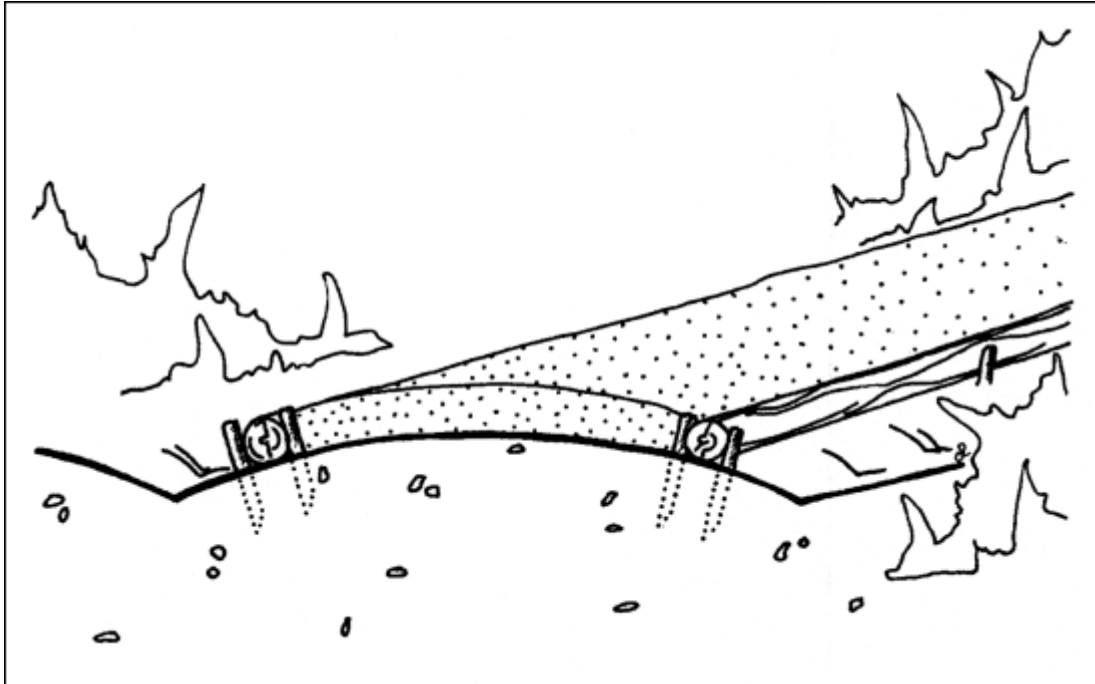

Trail Drainage Ditches

In areas where there is no ground cover or sod, ditches are dug parallel to the trail to discharge water to natural low areas and water courses, or across the trail downslope through culverts or waterbars.

In areas where there is sod, remove sod layers before excavating the ditch. After excavating, line the ditch with sod.

Drainage Depressions and Dips

Of all the different drainage methods, drainage depressions and dips are the easiest to build, the least expensive, and the most unobtrusive. Wherever water collects naturally, drainage depressions should be built during initial trail construction or during maintenance.

Figure 22: Typical drainage depression

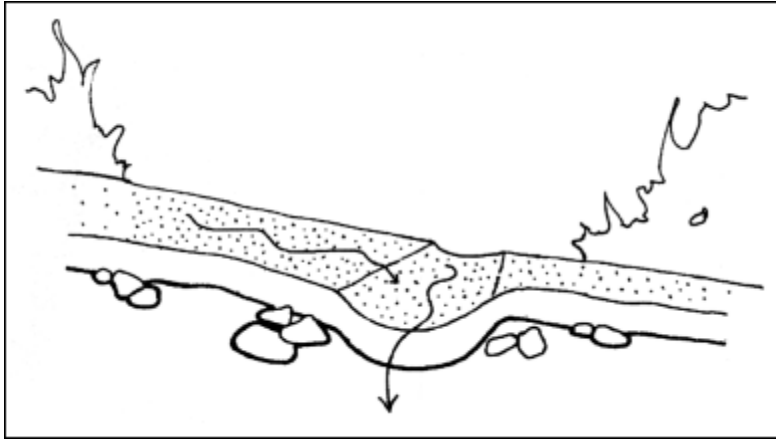

Drainage dips divert run-off from the trail tread to a side ditch or drainage ditch, or a natural low area. Placing gravel in a dip minimizes erosion.

Figure 23: Drainage dip

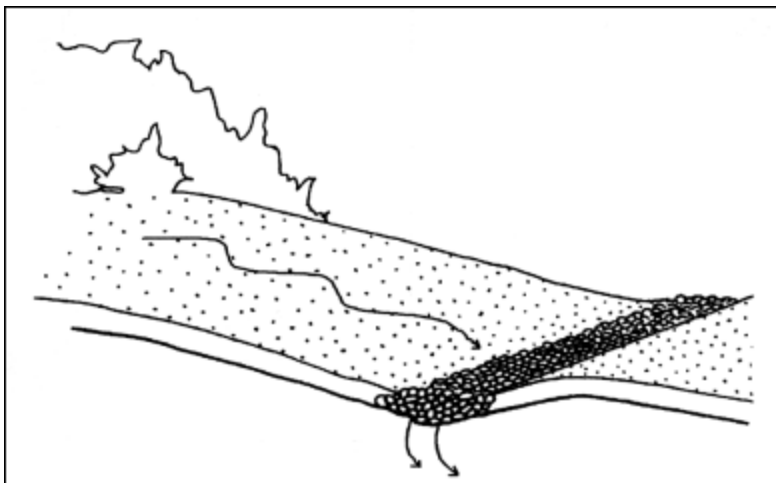

Cross Drains and Waterbars

Cross drains are used to intercept water on slopes or in shallow ditches and shed it to the lower side of the trail. Cross drains usually include a log, square cut timbers, or local rocks to support both sides of a drainage channel of coarse gravel.

After excavating a trench at an angle across the trail tread, logs or rocks, depending on what is available, are placed in the trench. The cross drains reinforce the correct angle and slope to flush fine sediment. Cross drains made with logs should not be built on bicycle trails, as they may be slippery.

Waterbars are used to divert water off the trail tread. Two types of water bar construction are shown here, log and rock waterbars.

Figure 24: Log waterbar

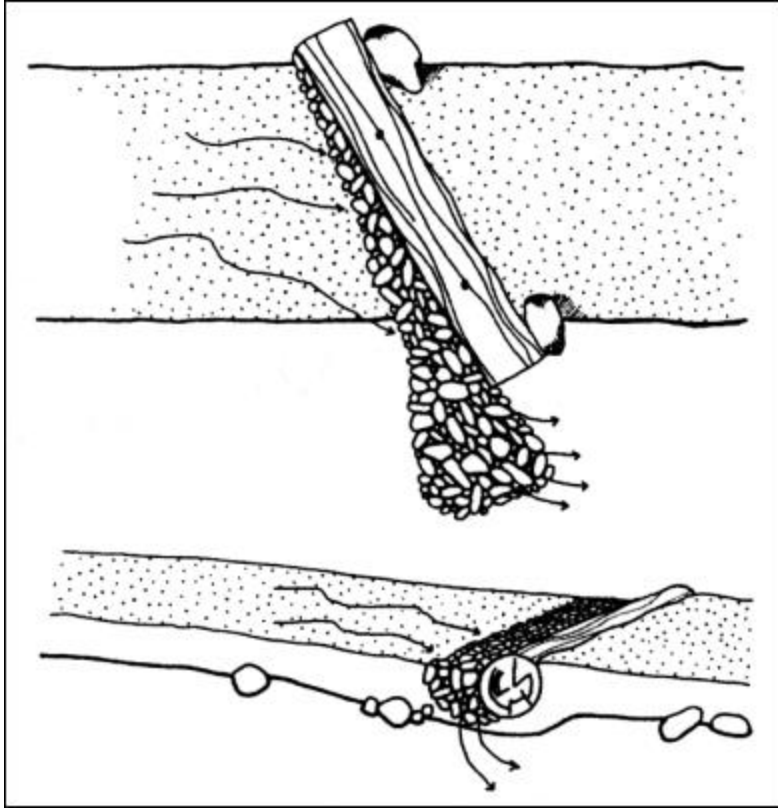

Overlap rocks to make an effective diversion.

Figure 25: Rock waterbar

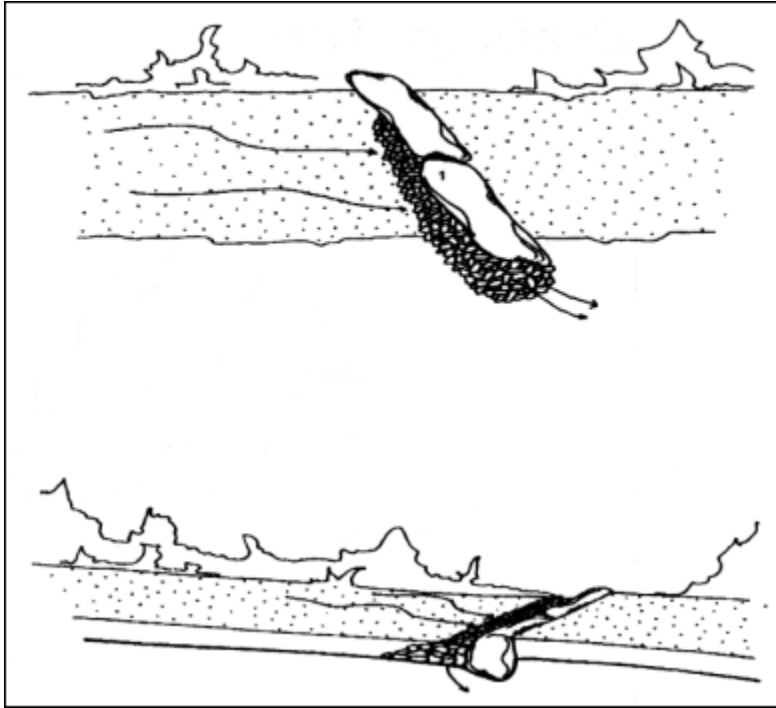

Culverts

Plastic (PVC) or metal culverts are used on small drainage channels where drainage dips or other structures are not adequate. The type of culvert depends on the seasonal high water levels.

- Large rocks placed around the ends of culverts stabilize the fill material and hide the ends of the culvert pipes.
- Cutting the pipe ends at a 45 degree angle reduces the visual impact of the culvert.
- The area around the culvert is generally backfilled and compacted.
- Granular surfacing over the pipe provides the tread.

Constructing rock culverts with local materials can be an alternative to metal or plastic culverts. However, this type of drainage channel is not appropriate for barrier-free trails, bicycle trails, or high standard foot trails.

1. Water is diverted from the ditch into the culvert

Figure 26: Typical culvert with ditch

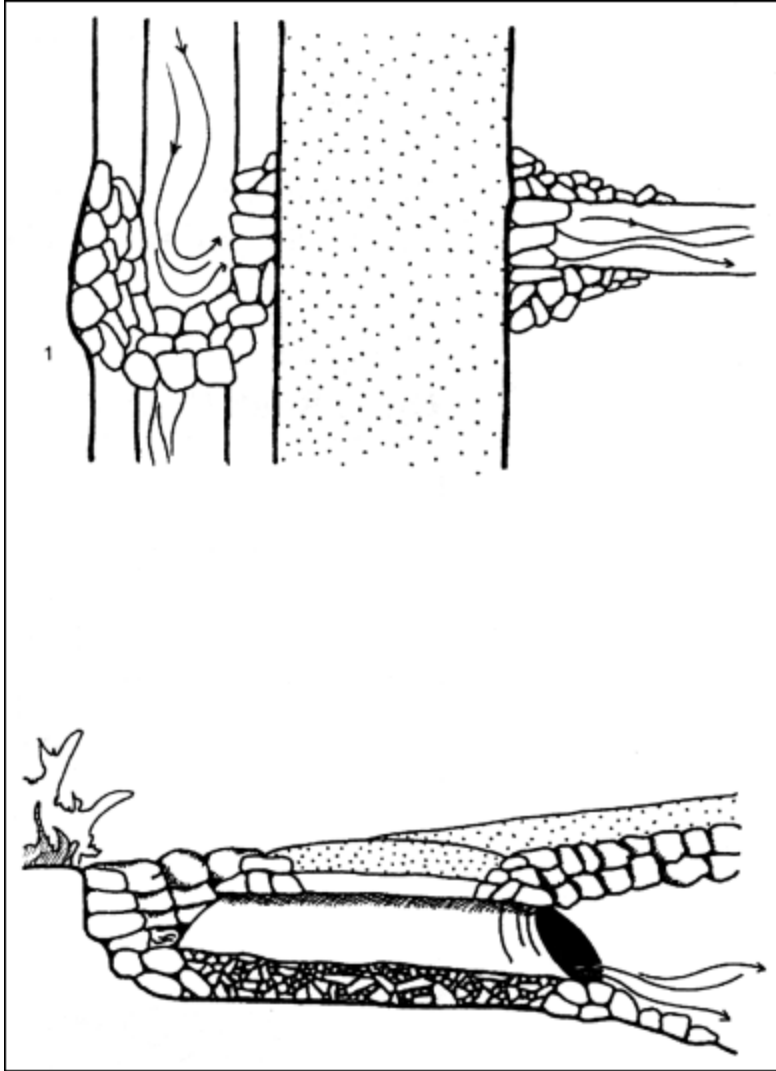

The rock culvert is one that can be built on trails in back country areas.

Figure 27: Rock culvert

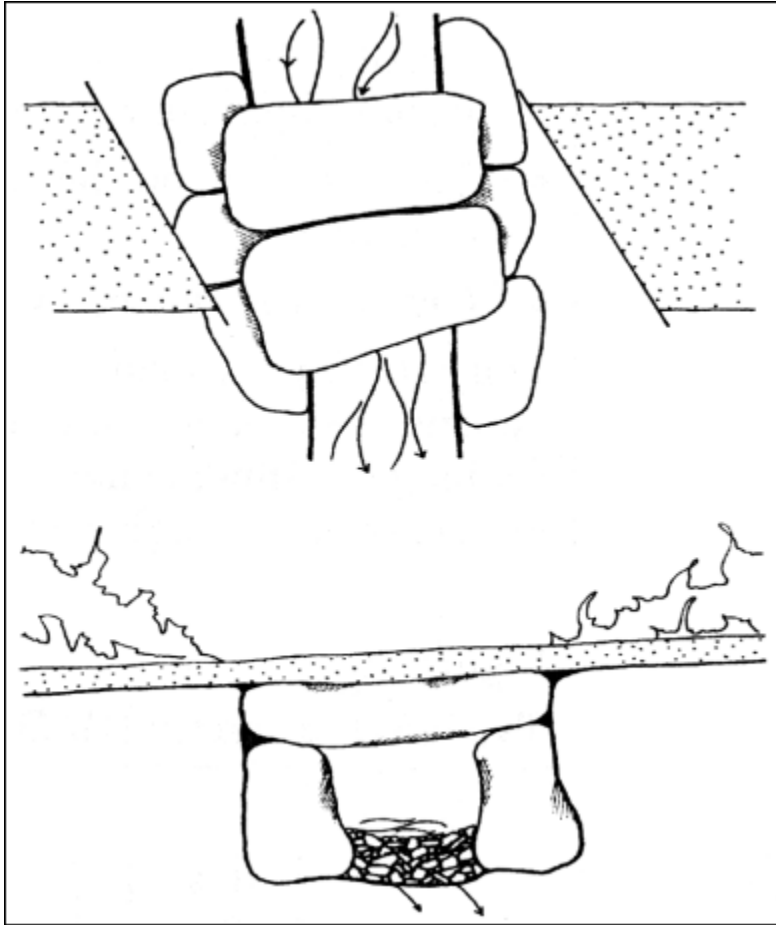

Open rock culvert. This type of culvert works in a similar way as a waterbar, and can be used on trails in back country areas.

Figure 28: Open rock culvert

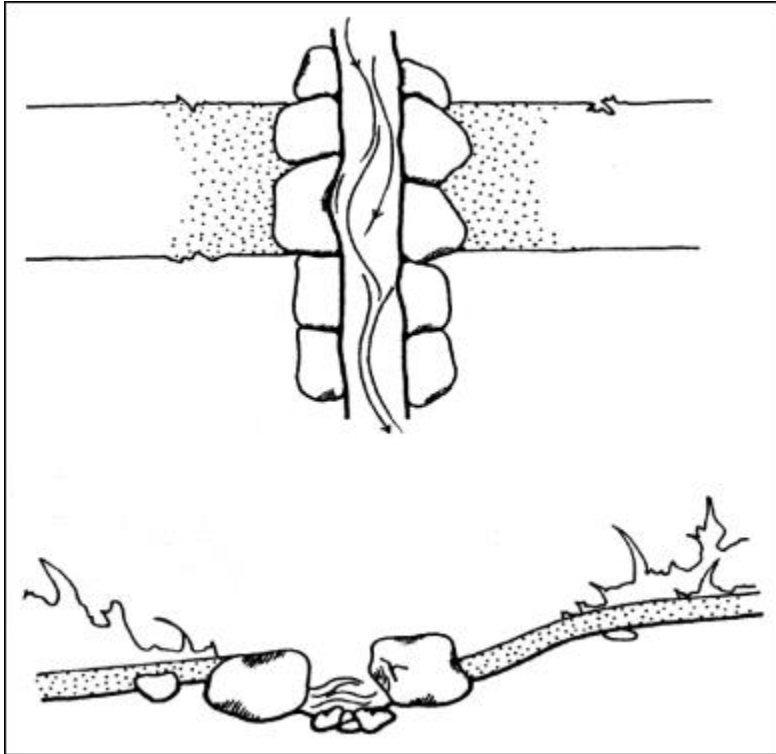

Drainage Turnpike

A turnpike routes water away from the trail on both sides of a raised trail bed. Stakes or rocks should be placed at intervals to retain logs supporting the raised trail tread.

This type of drainage is expensive to construct and maintain, but may be needed where the terrain does not allow for any simpler methods.

1. Material removed from ditches on both sides
2. Removed material is piled between ditches to build up trail base
3. All cut edges are sloped for stability
4. Gravel capping: 60 cm wide

Figure 29: Turnpike

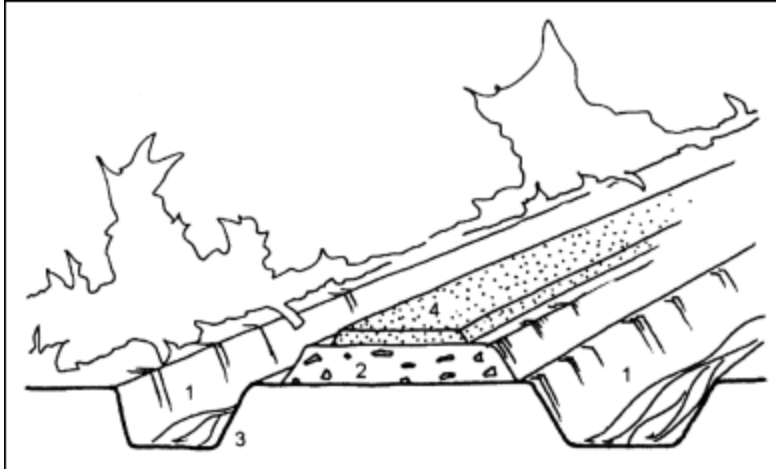

Switchback Drainage

Proper drainage at the top of a switchback is essential. Water must be collected and diverted, and the trail tread sloped correctly, or the corners and lower sections of the switchback will erode.

1. Drainage ditch on uphill side of upper section of switchback protects turn area
2. Retaining wall used to support upper section
3. Lower section also ditched on uphill side, then drained under the trail

Figure 30: Switchback drainage details

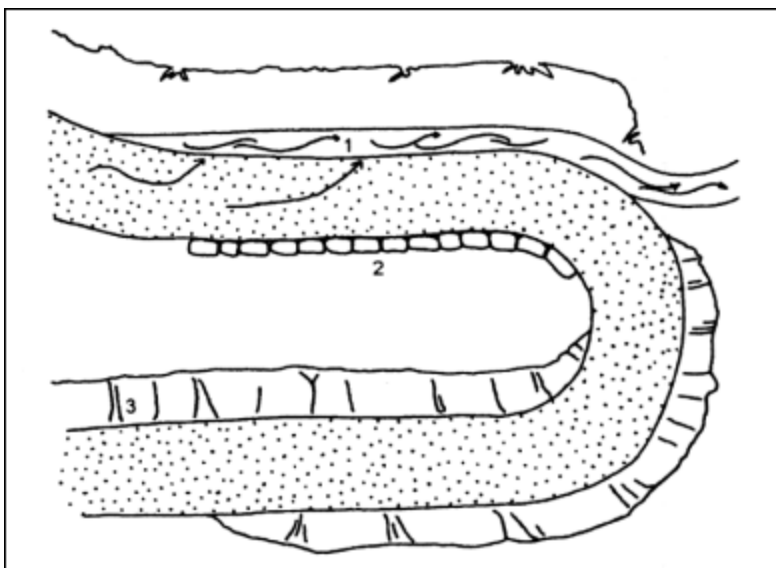

Debris Removal

Removing construction debris from the trail area reduces the fire hazard and enhances the natural appearance of a trail.

To ensure the cut ends of trees are not visible to trail users, small trees should be dragged butt end first away from the trail. Small branches and saplings are cut up and scattered, usually a minimum of three metres from the trail.

Cut trees may be used to construct bridges, steps, corduroy surfaces, or for trail tread edges.

By placing vegetation debris along the ground rather than in piles, it will decompose faster. This will help avoid the problem of vegetation debris clogging natural drainage courses.

[[Top](#)]

10.4.4 Trail Bridging

Wherever trails cross rivers, streams, bogs, marshes or sensitive plant habitat, such as an alpine meadow, some form of trail bridging is required in order to protect the trail user and the environment.

Bridging features can range from simple stepping stones, boardwalks and timber bridges with decking, to more elaborate engineered structures.

The type of bridging selected will depend primarily on whether the trail is crossing land or open water, as well as:

- the type of trail being served, (Type I - V);
- the needs and limitations of trail users (hikers/equestrians/ cyclists);
- the anticipated level of traffic;
- the sensitivity of the surface material/plants, or the breadth and depth of the watercourse, being crossed; and
- seasonal variations or local conditions.

For many trails in provincial forests, trail builders will use building materials found along or near the site.

With these materials, it is particularly important that effective construction techniques are employed that:

- can withstand the effects of weather and wet environments;
- can withstand the impact of boots, hooves and wheels; and
- provide safe public use.

Bridging Wet or Sensitive Areas

Where trails cross wetland areas:

- bridging must allow for adequate drainage channels and be able to withstand water level fluctuations;
- the bridging surface should preferably be above maximum water level, or should be constructed to withstand flood conditions; and
- the trail surface should not be submerged for any portion of the trail use season.

Log Rounds and Stepping Stones (Only suitable for hikers)

These two options use materials generally found onsite. If carefully placed, an aesthetically pleasing effect can be achieved. Rounds can be set in a line, alternated to match walking steps, or set side-by-side to form a walkway.

Log rounds should:

- be made of cedar if possible (or pressure treated, or painted with a stable, non-toxic preservative);
- be rough cut with a minimum diameter of 300 mm;
- have the bark removed;
- be set to a minimum depth of 500 mm; and
- be bedded-in firmly to promote stability and reduce cracking.

To reduce slipperiness of log rounds:

- a slightly sloping surface cut will help drainage;
 - shallow chain saw cuts can be added; or
 - chicken wire can be stapled to the surface.
-
- Tops of log rounds are sloped to drain and prevent rotting
 - Chicken wire on surface prevents slipping
 - Wide rounds are most stable
 - Cedar rounds are most durable

Figure 31: Log rounds

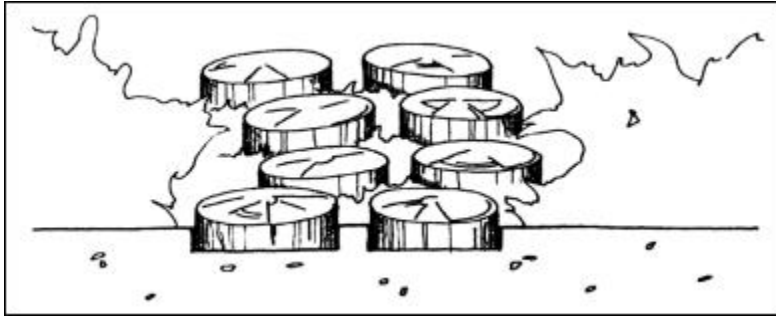

Stepping stones can provide a long-lasting aesthetic solution to crossing wet areas. Any size and shape of rock can be used, as long as one surface is relatively flat. Larger stones are less prone to dangerous shifting under a hiker's weight.

Stepping stones should be stable and not protrude too high above the ground surface or people are apt to avoid them.

- Stepping stones can be used across marshy areas or running water
- At streams, tops of stepping stones must be above the highest flood level

Figure 32: Stepping stones

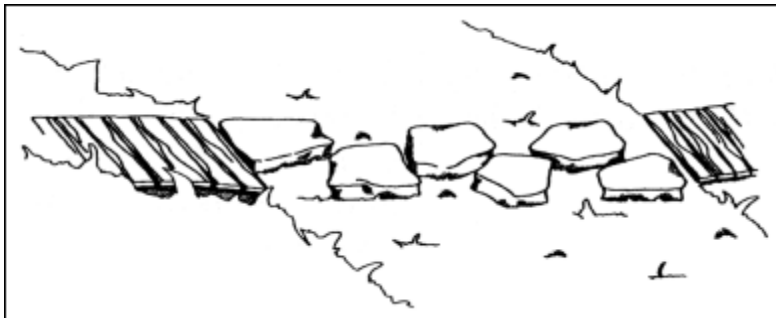

Rock Treadway

A rock treadway is simply a more extensive use of rock than stepping stones. Small rocks are used to infill the space between larger stones, creating a relatively flat surface. Small rocks will sink into the surface if used alone.

In some high use locations, it may be appropriate to firm up the treadway with a grout of soil cement, a mixture of parent material (preferably gravel), cement and water. Local gravel set into the surface of the soil cement will restore an aesthetic appearance. When a rock treadway is made impervious to rainwater, surface slope and drainage ditches may have to be incorporated.

Corduroy Trails

A corduroy trail has a walking surface composed of cut logs resting directly on the ground.

This technique is quick and crude, and requires few construction skills. *However, it uses a lot of wood and is quite limited in its effectiveness.* On flat, wet ground, in areas with only moderate use, corduroy provides hikers with a dry crossing. However, wet ground is usually unstable, and unless very well secured, cordwood pieces tend to become canted to one end. Peeled logs are slippery when wet and this invites the creation of an easier path to the side, often resulting in environmental damage.

Construction: Peeled logs are placed directly on the ground in approximately 2.5 to 3 metre sections and secured with stakes at either end. Spaces of at least 350 mm are left between sections for drainage channels.

Figure 33: Corduroy showing spacing for drainage channels

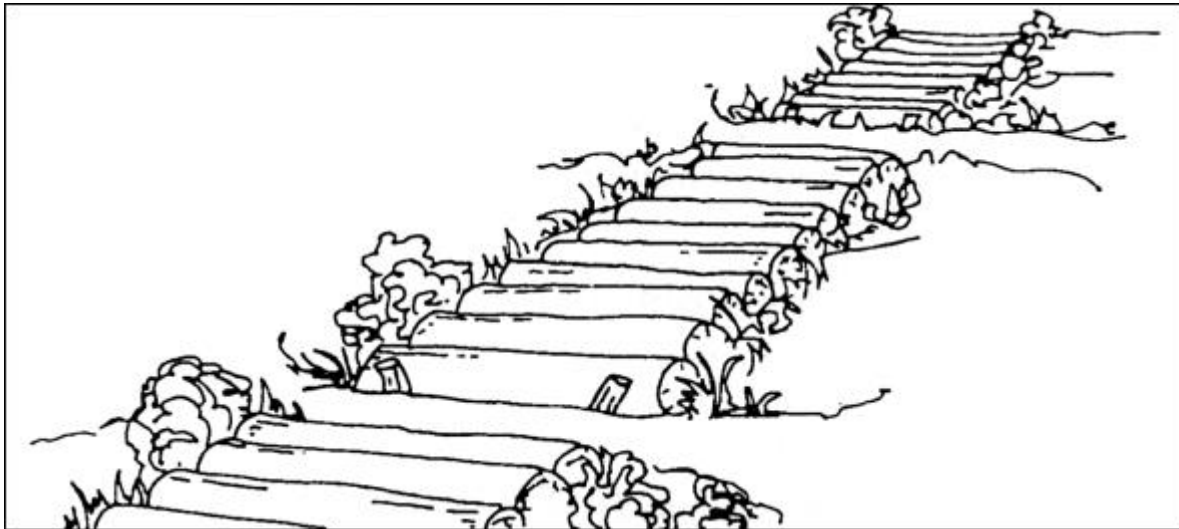

Flexible Plank Decking

This form of bridging is used in areas of *shifting sand* to help control erosion.

Treated planks lie on the ground, partially supported by a cable. The cable's primary function is not weight-bearing, but to prevent the planks from drifting.

- In one method, a lateral hole is drilled through each end of the plank and the planks are then strung together with cable.
- An alternative method has the cable running through staples on the plank surface.

Figure 34: Flexible plank decking

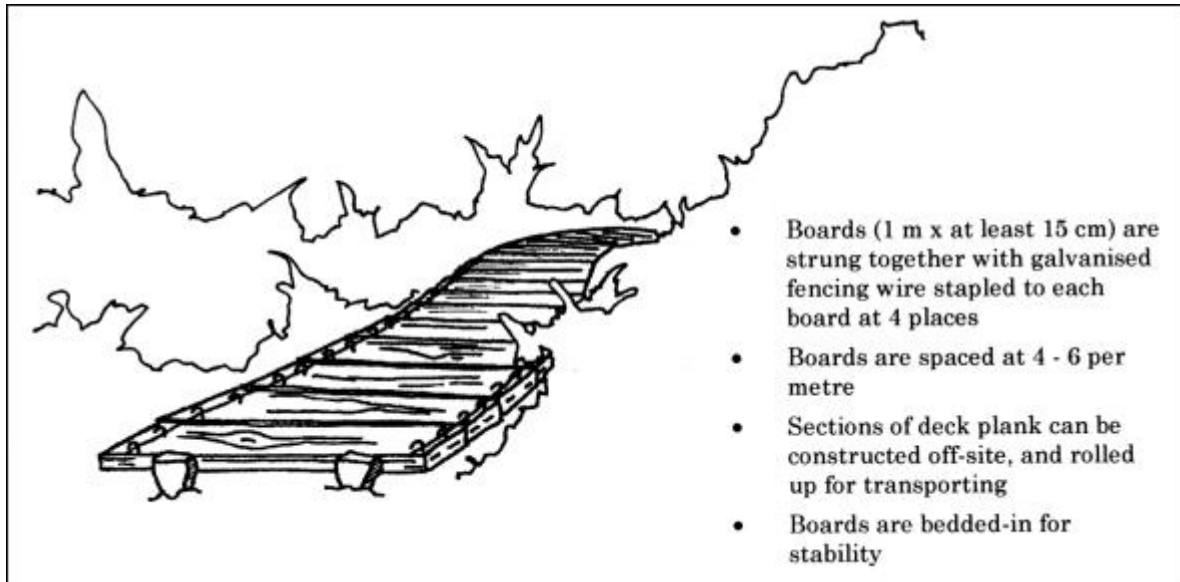

Trail bridging over shallow water

Trail bridging over shallow water is more elaborate and costly to build. Raised plank bridging, known as boardwalk, may be constructed, or for deeper water, decking may be secured to styrofoam floats which are well-anchored to bottom materials.

Boardwalks

A boardwalk is constructed in sensitive areas where crossing is otherwise very difficult or could result in unacceptable environmental impact. Boardwalks should be:

- separated from the underlying surface either by resting on sills and stringers or by elevation on posts;
- considered in high-use areas or where access for persons with disability is desired;
- used for nature interpretation to allow close access to features; and
- used to provide clean, dry footing across muddy areas.

A boardwalk is an expensive and obtrusive element in the landscape, and should be used selectively. The need for a boardwalk should be avoided, wherever possible, by aligning the trail on well-drained soils or by utilizing drainage and on-grade trail construction techniques. In areas with low use, a width of 500 mm rather than standard 750-1000 mm will reduce costs.

The benefits of properly constructed boardwalks include:

- low maintenance and relatively low impact;
- minimum impact across sensitive alpine bogs, swamps or around lake shores prone to flooding; and
- no drainage of a sensitive area.

Posts should be driven into the ground with a sledge hammer to reduce interference, **not** dug in.

On flat country, the visual impact of boardwalks can be reduced by incorporating gentle curves compatible with the visual surroundings. Boardwalks made of cedar will bleach to an acceptable natural toning in most weather conditions.

Boardwalks should be located close to the ground to allow grasses and small shrubs to grow back around the structure and between the deck boards. Walkers' feet will tend to trim off the growth at board height.

Figure 35: A curved boardwalk reduces visual impact

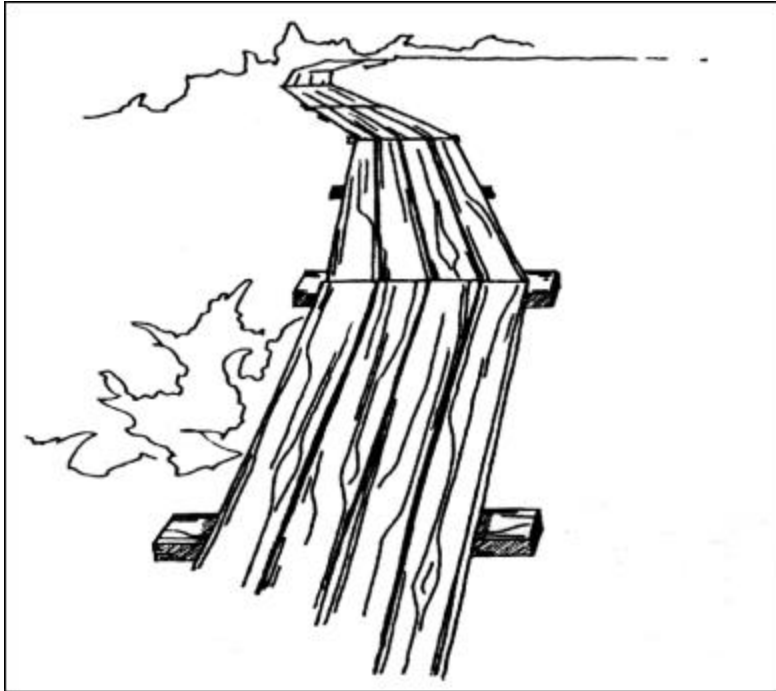

Construction of boardwalks should include:

- a ramp for smooth access or, alternatively, steps at either end;
- non-slip ramps for barrier-free access (dirt or grip-surfaced wood);
- stepped sections for changes in elevation (boardwalks have to be horizontal);
- concrete footings in high use areas for stability and longevity; and
- log decking laid at a right angles for easier walking or plank decking (rough-sawn and laid with 10 to 20 mm spacing).

There are many styles of boardwalks:

a) Log or plank decking on stringers

In this method, either logs or planks are laid perpendicular to the length of the trail. This requires the use of a log or rock sill placed underneath the stringers to which the decking is applied.

Figure 36: Cross-section, elevation and plan view of log decking on stringers

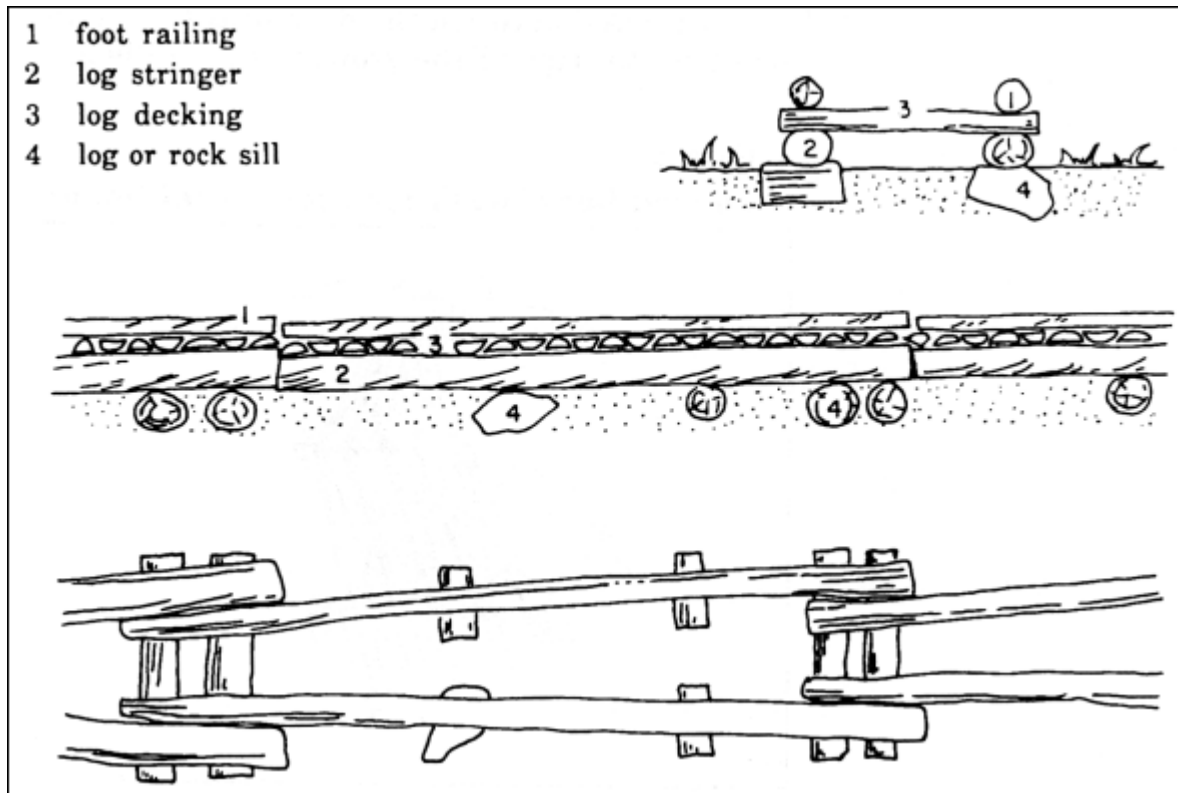

When log decking is used, the logs are split and laid down in an alternating fashion, first with the rounded side down, then up. If planks are used, the foot railing shown in the above drawing is not necessary.

b) Plank decking on sills.

In this method of bridging, the decking is laid parallel to the length of the trail on log sills. Sills should be spaced so that the degree of flex in the decking is minimal.

The use of raised single or double planks is an effective way of traversing soft, wet areas.

Hardwood planks are strung across swampy ground on support logs laid on the ground across the trail. Two adjoining plank ends rest beside each other on one log to conserve material.

This simple, inexpensive, narrow pathway is *only suitable for remote areas with low use*. Users need to briefly step off the walkway to pass.

Figure 37: Single plank decking on sills

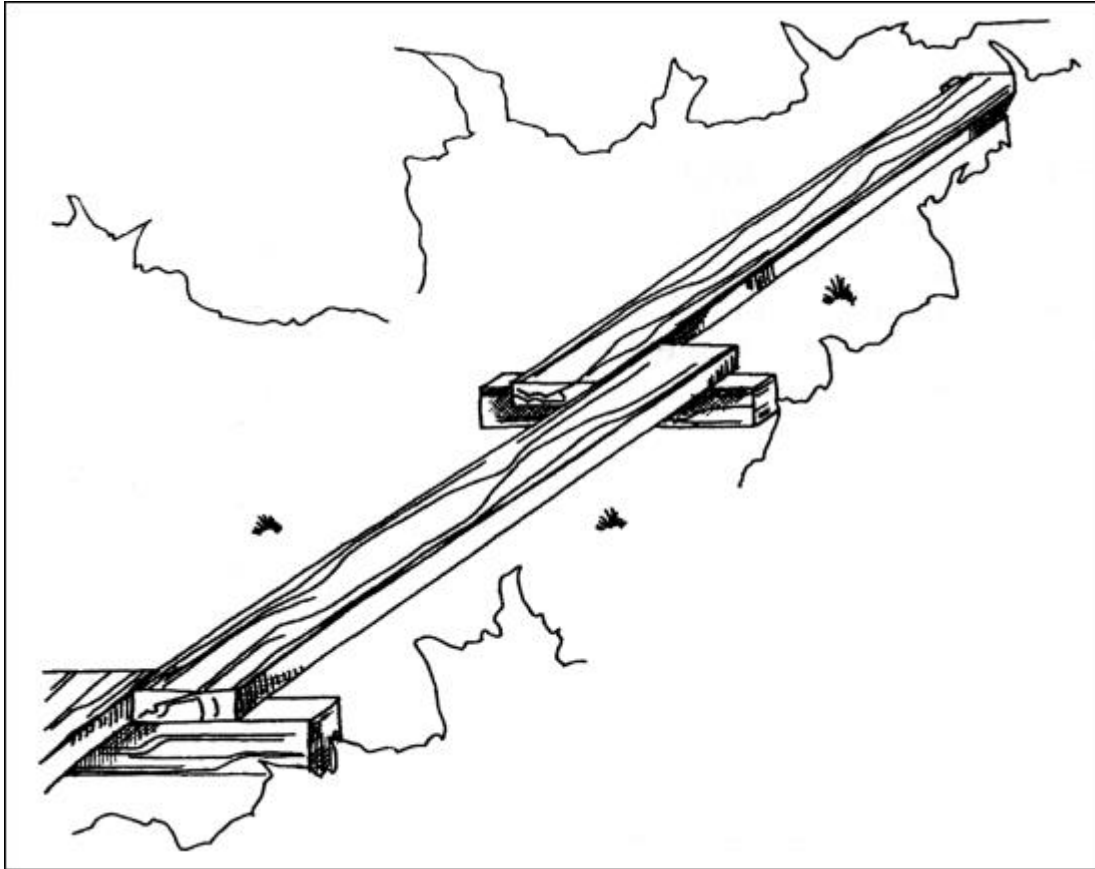

c) Post supported boardwalk

This is a strong design suited to high-use areas. With ground contact limited to the small area of the vertical posts, there is minimal impact on the environment.

Figure 38: Post supported boardwalk

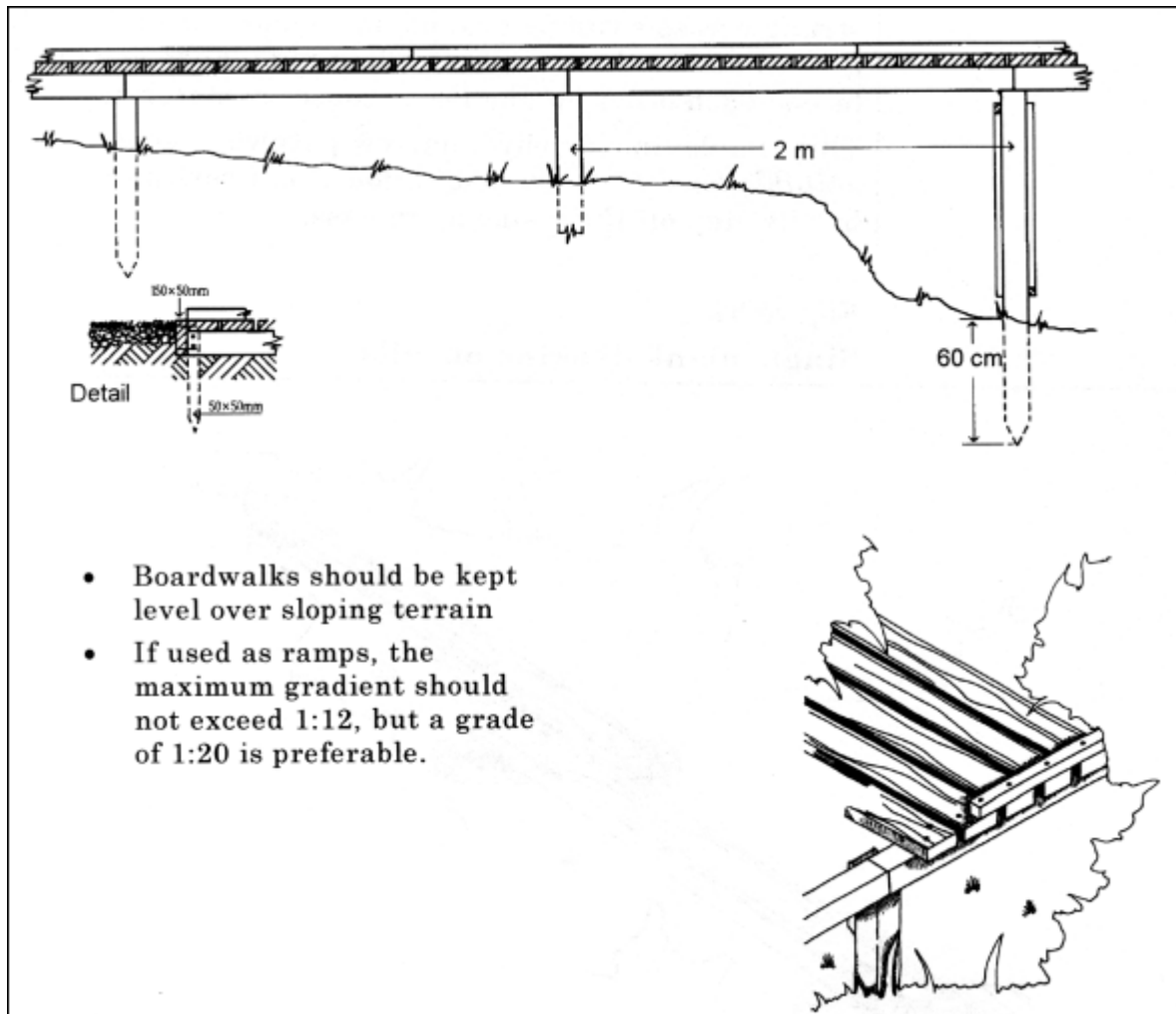

d) Post and sill with handrail

This design provides trail users with a high degree of security. It is suited to high use areas and locations with bicycle traffic. The boardwalk site should be easily accessed in order to carry in the dimensional lumber required. There will be some damage to vegetation where the sill rests on the ground.

1. Sill supports stringers clear of ground.
2. Post tops sloped to prevent rotting from rainwater.

Figure 39: Post and sill boardwalk with handrail

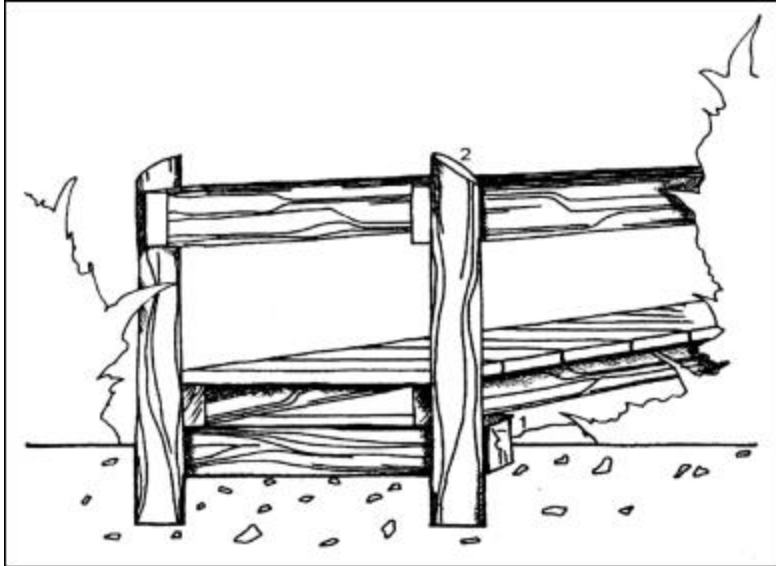

e) Standard duckboard

Duckboard is small-width boardwalk that is often prefabricated and flown or carried to the construction site. Because of its light weight, some 12-15 three-metre lengths can be lifted per helicopter sling load.

This design is best suited to low/moderate use trails for hikers only. Duckboard requires posts to support it and a certain amount of soil strength to hold the posts.

Figure 40: Standard duckboard

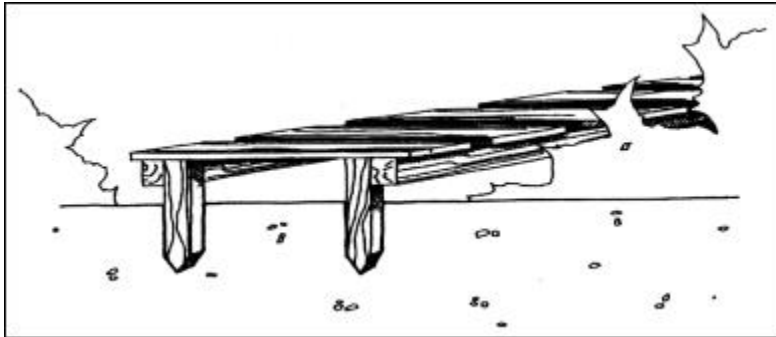

f) Duckboard with stringer

A duckboard with a stringer provides it with more "float," which is important in soft surface areas. The stringer shown is a quarter-round post. Stringers rest directly on the ground and will damage any vegetation underneath.

Figure 41: Duckboard with Stringer

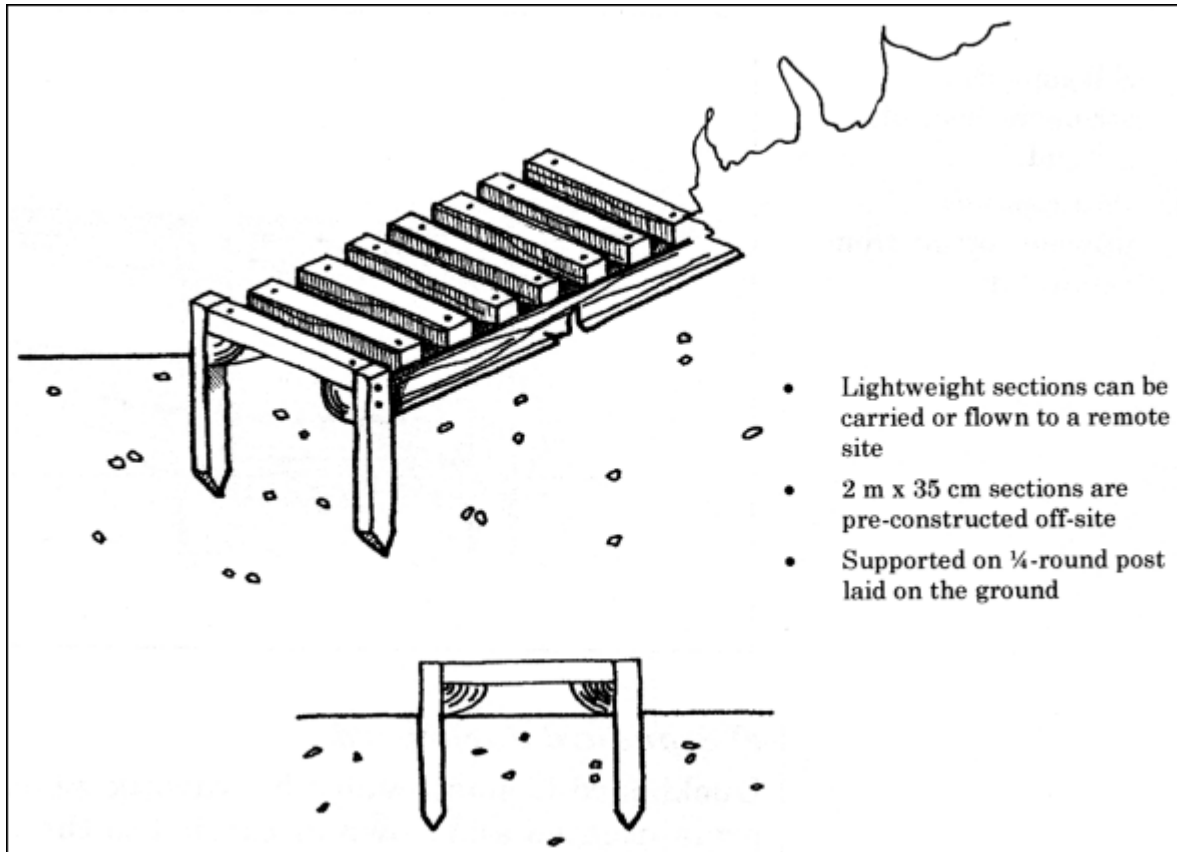

Bridging Open Water

Bridges may be used to cross rivers, streams, wetlands or areas of shallow water. Bridge location and design should take into consideration:

- stream flow characteristics;
- peak run-off periods;
- bank and stream bed erosion potential;
- fish habitat;
- snow loads and ice conditions;
- adequate clearance on navigable watercourses to allow for boats; and
- proper alignment and orientation to the trail tread.

Specifications for a bridge should include structural strength, width, need for railings, and the type of construction material used for decking.

Handrails should be used on all bridges where the decking is more than 1.2 metres (4 ft.) above the water, or where bridges cross fast-moving water. For Type IV and V trails, a handrail may be optional.

On semi-primitive hiking trails, bridges may consist of two logs placed side-by-side with their tops flattened for easier walking. Suspension bridges, rafts and bosun chair type crossings add a

challenging element to water crossing for experienced hikers, but are not appropriate for trails used by the general public.

Bridges on equestrian trails or in areas of moose wetland habitat should be strong enough to support large animals.

Trails designed for barrier-free access or mountain bike use should consider any specific requirements for bridge access, width, surfacing and handrail height.

Fords and Stepping Stones

Shallow fords can be an attractive feature on equestrian and mountain biking trails. From a management point of view, a ford is a low-cost and maintenance-free option. Hikers in remote back country areas, especially on Type IV and V trails, accept stream fording as a reasonable proposition.

The best location to cross rivers and streams should be carefully investigated:

- Find a wide, shallow section of river.
- Depth during the use season should be < 60 cm.
- Avoid uneven stream beds and fast-flowing water.
- Move rocks to create an even stream bed if necessary.
- Position stepping stones across small streams to aid hikers and mountain bikers.
- Consider possible erosion at entry and exit points.
- Mark the trail clearly on both banks. For Type I-III trails, provide warning signs on both banks.

Above all, user safety must be closely considered.

For faster flowing streams or rough crossings on Type I-III trails, a bridge should be constructed. On Type IV and V trails, users should be informed *at the trailhead* about the river crossing, and any need for ropes and/or special expertise.

Simple Log Bridges

Single log or two-log bridges may be used where the crossing is relatively free of hazards and use is low. The following should be considered when building simple log bridges:

- record spring high water marks;
- build at least 0.5 m above the high water mark;
- start in late summer or fall when the stream banks are dry and stable;
- use peeled logs that are straight and uniform in diameter, and with the least of number of branches;
- use one stringer more than 0.3 metres (12") in diameter at its thinner end or two stringers side by side;

- place trunk stems in opposite directions for maximum strength and more consistent width on two log bridges;
- limit bridge spans according to the size of the log - the log should span the water course and extend at least 1 metre over each bank;
- use diagonal cross cuts 5 mm deep over the flat surface of the log to prevent slipping;
- line banks of the stream or water course with larger rocks to help prevent scouring and disturbance of the bridge;
- install handrails on lengthy or dangerous crossings; and
- cut notches in the sill log so that the sides rather than the bottoms of the stringers are touching (prevents rocking of the stringers sideways - see diagram).

1. Notch to provide two points of contact on side of stringer and prevent rocking.
2. Stringer pinned into place.
3. Gap to one side - this will rock.

Figure 42: Notching log stringers

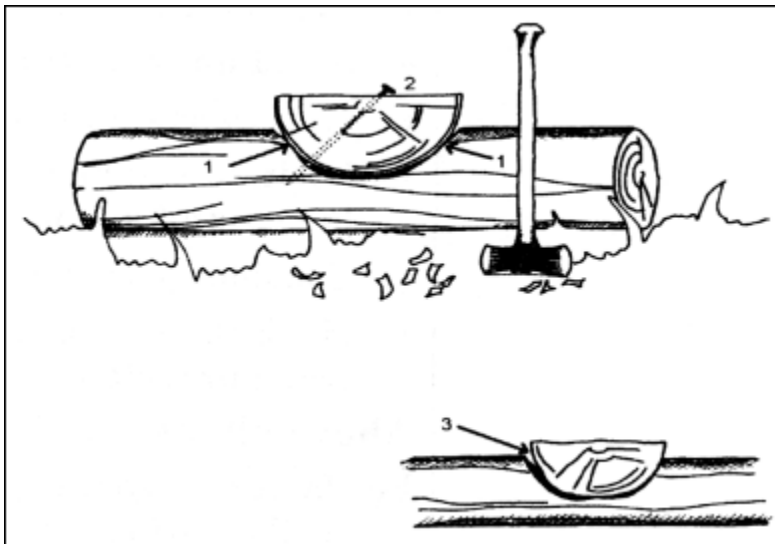

Additional pointers

For bicycle safety, bridge decking should be laid perpendicular to the trail direction.

In high-use areas, or for wide spans, metal I-beams can be used instead of wood stringers. The top surface of the I-beam should be faced with lumber (bolted on) in order to nail down the decking. Use of an I-beam provides a long-term solution to stringers being weakening from moisture (e.g., near waterfalls).

Figure 43: Single-log bridge with handrail

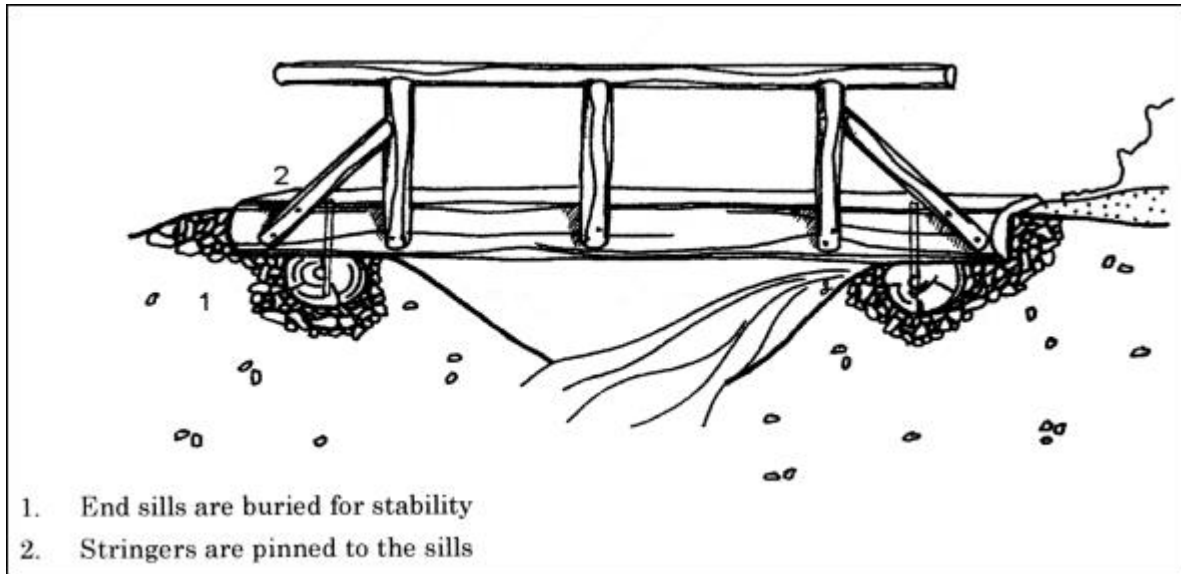

Figure 44: Simple two-log bridge

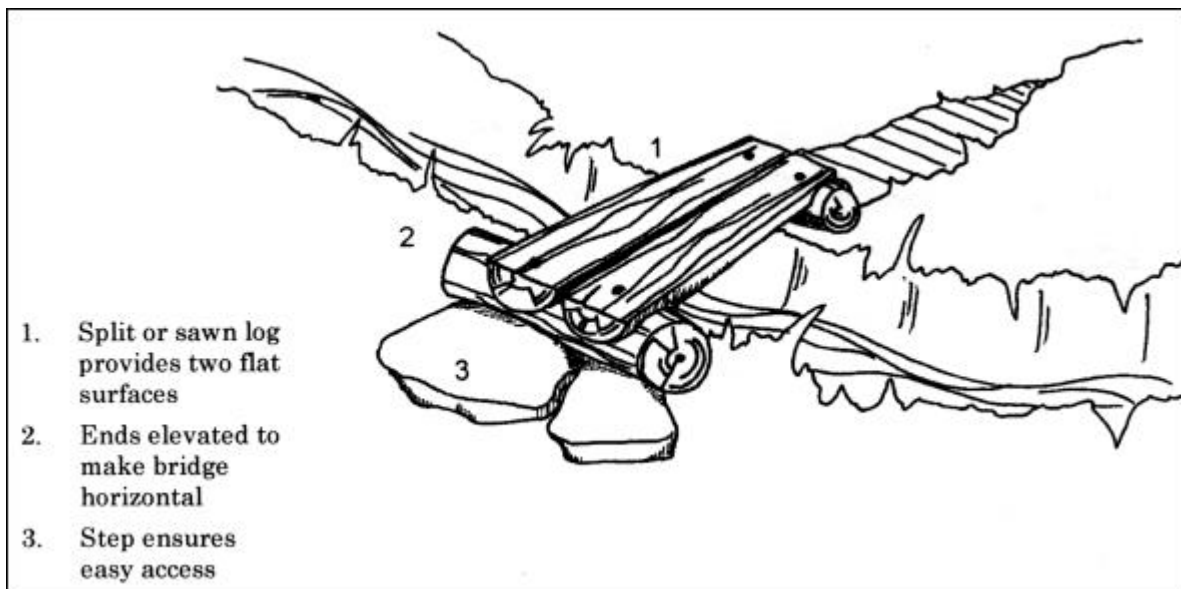

Figure 45: Three-stringer bridge

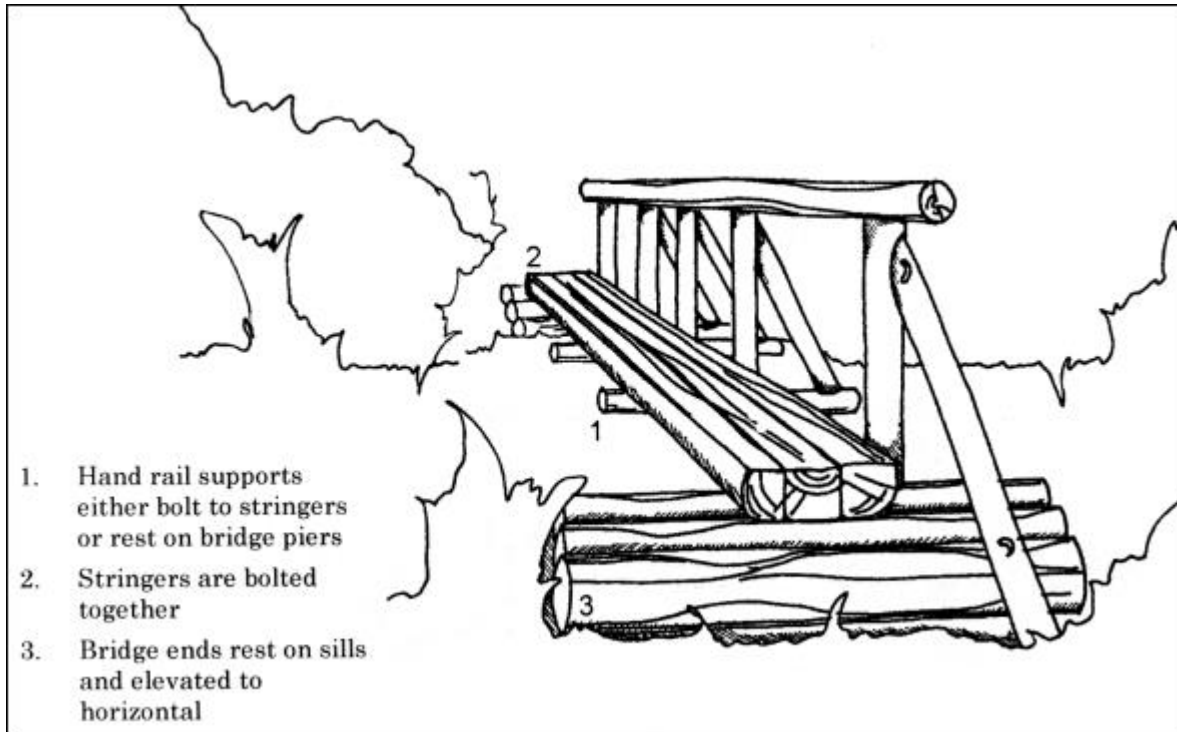
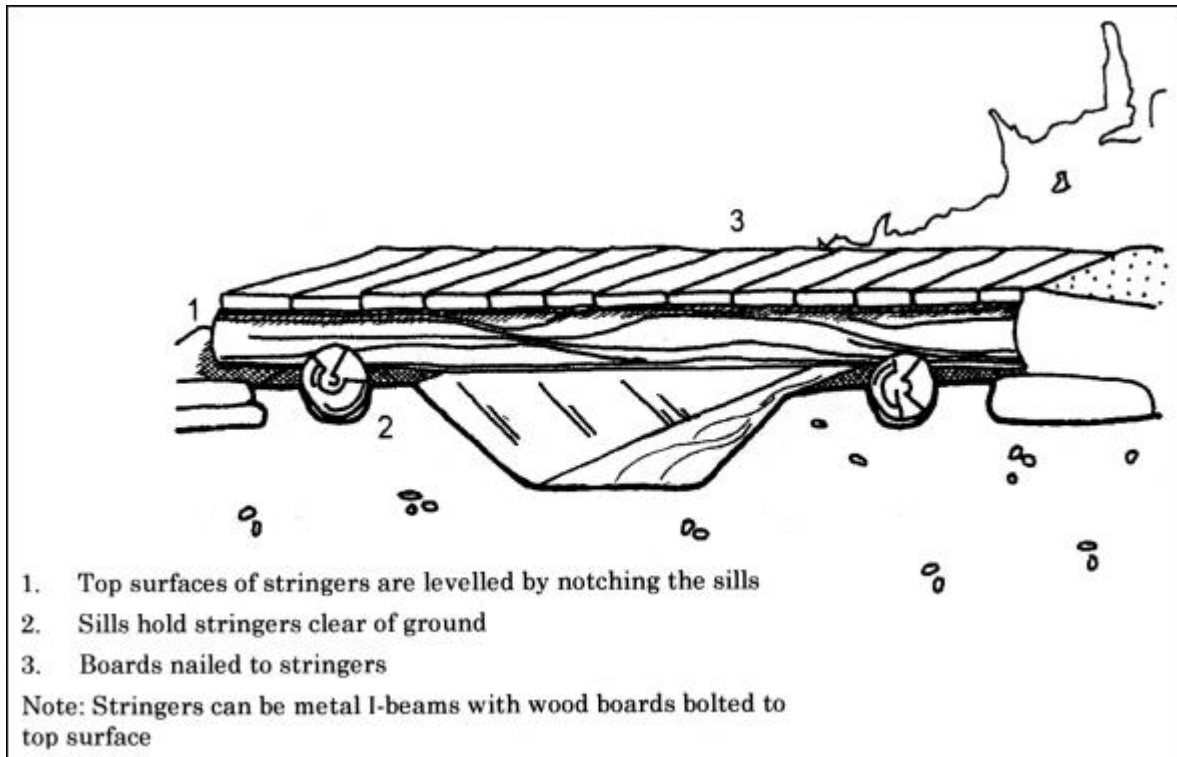

Figure 46: Log bridge with timber decking



Stringer dimensions

The span diameter table provides recommended minimum diameters for various bridge spans (based on a two-stringer bridge). Three stringers should be considered in heavy snow country.

Span Diameter Table*

Clear Span (metres)	Douglas-fir Timber (cm) Width x Depth	Peeled Log Diameter (cm)		
		Fir	Spruce	Cedar
0 - 4.5	15.5 x 20.5	22	24	26
4.8 - 6	20.5 x 26	27	29	31
6.3 - 7.5	20.5 x 31	31	34	36
7.8 - 9	31 x 31	36	38	41
9.3 - 10.5	31 x 36	40	43	46
10.8 - 12	36 x 41	43	49	51
12.3 - 13.5	41 x 41	47	52	56
13.8 - 15	41 x 46	51	57	61

* Dimensions provided by Nelson Forest Region

Figure 47: Bridge with decking and handrails

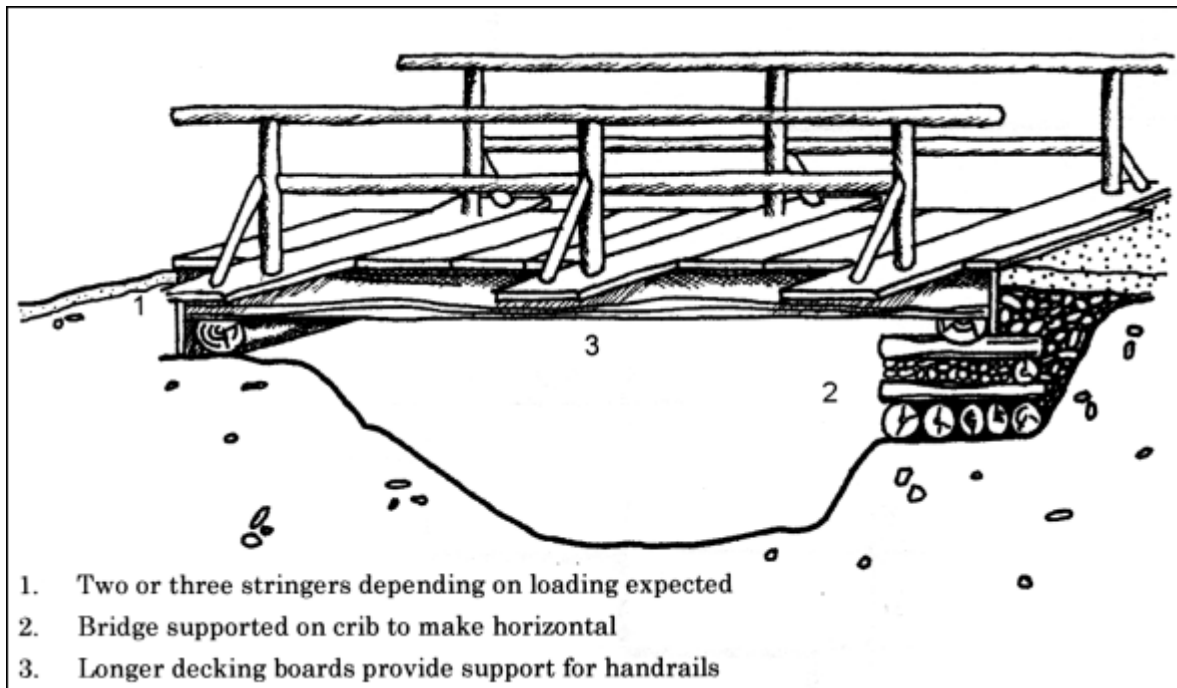

1. Two or three stringers depending on loading expected
2. Bridge supported on crib to make horizontal
3. Longer decking boards provide support for handrails

Engineered Bridges

For an added margin of safety, custom bridges can be designed for a particular purpose or location, and usually involve using materials and components that exceed the load requirements of the structure. There are many interesting and functional designs for engineered bridges that

can be put together with simple tools in a back country setting. A professional engineer should be consulted.

[[Top](#)]

10.4.5 Trail Steps and Ladders

Steps

Steps are used on short, steep trail sections to ensure user safety and to help prevent erosion. A series of short flights of 14 steps or less, with ample landings in between, is preferable to a single long flight. Handrails should be installed on at least one side where flights are steep or long.

Acceptable stair proportions must be used in step construction. The recommended formula is:

Height (cm) X tread depth (cm) = 450.

For example:

- 1) 10 cm rise requires a 45 cm tread depth.
- 2) 15 cm rise requires a 30 cm tread depth.

Tread depth should not be less than 30 cm.

Figure 48: Rise to run diagram

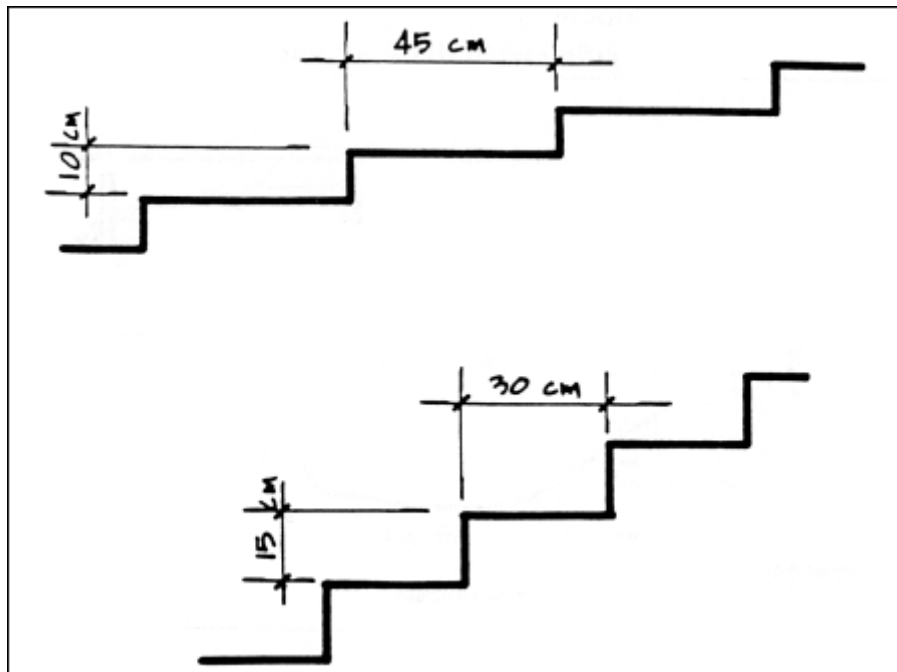

Consider safety

Riser heights of more than 20 cm (8 in.) are tiring for ascending hikers and difficult for children and elderly walkers. Such a rise is even more difficult for descending hikers, and may be dangerous for people who are tired.

On steep ascents, steps are critical for preventing soil erosion and stabilizing slopes. The basic purpose of steps is to scale a steep vertical rise on the trail while permitting lower grades between flights. While this helps hikers, it also slows water and retains soil.

When building steps, either of wood or rock, it is best to:

- work from the bottom up to determine the best placement of steps and optimal stabilization;
- drain steps to the side to prevent premature wood deterioration and to retain fill material; and
- curve steps to follow the outside of a slope for drainage.

Wider steps appear to be less steep than narrow steps.

Boulder Steps

Boulder steps are far more desirable than log steps since they last longer and are more aesthetically pleasing. Over time, they will begin to look as if they were naturally in the trail, especially if they are placed carefully.

There are two basic designs for boulder steps:

- riser boulders set into the slope and backfilled; and
- overlapping tread boulders supported by smaller rocks and fill (see figure below).

Figure 49: Boulder steps

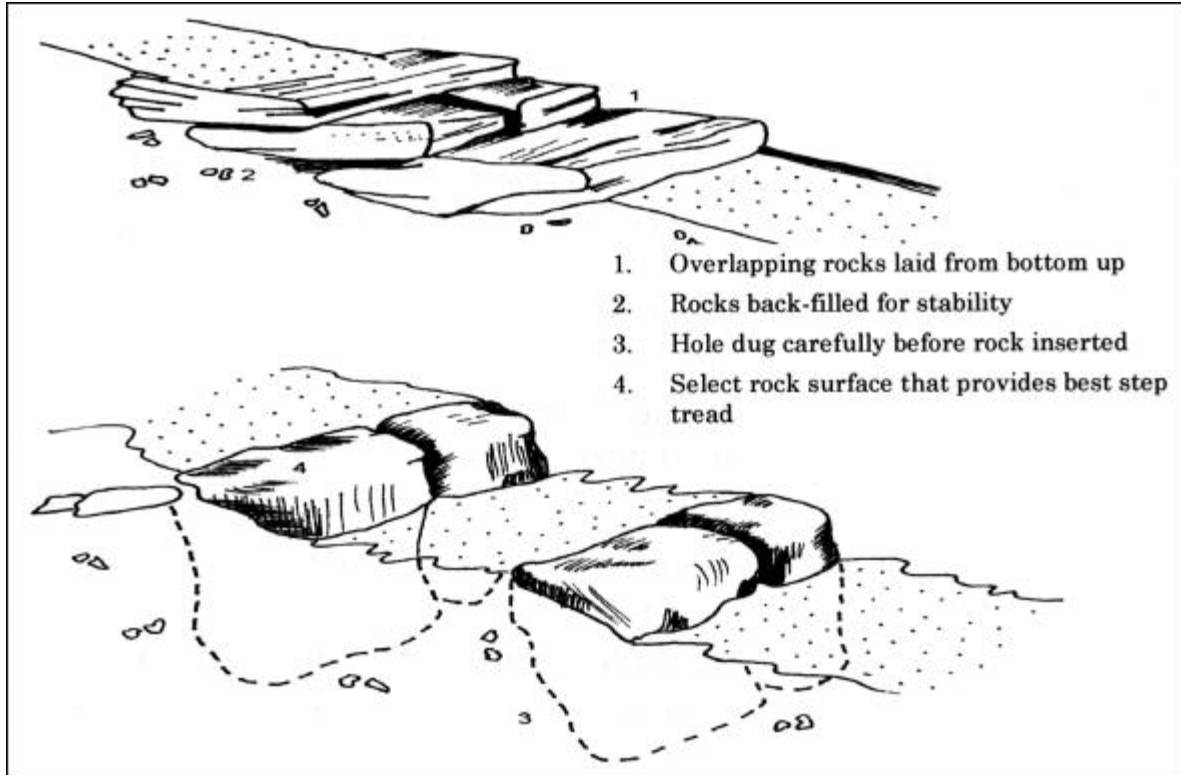

Log Steps and Stairs

Log or timber steps set into the ground are simple to build and are less expensive than steps supported by stringers. Either full or half logs may be used in construction.

Figure 50: Log steps

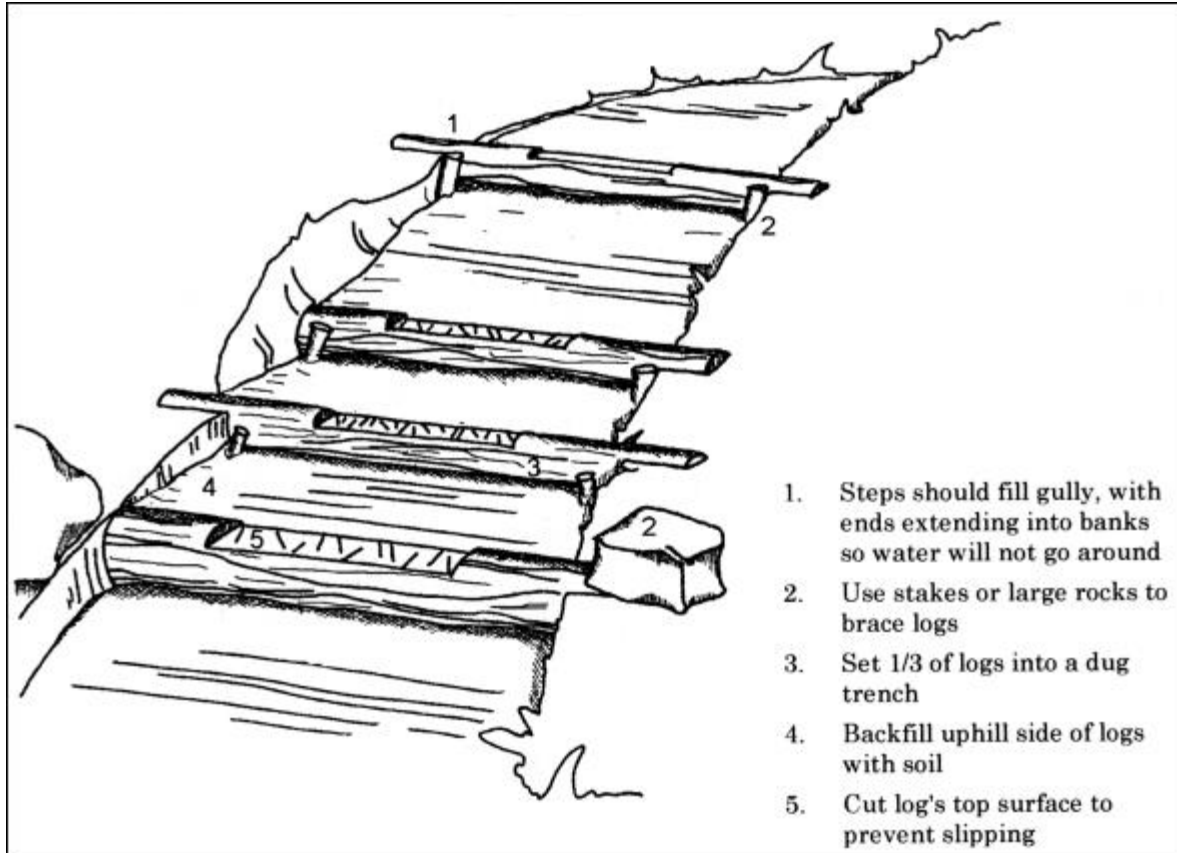

Timber Steps and Stairs

Timber steps are normally considered for intense use trails where long-term stability is desired. They should follow the contour of the land to minimize site disturbance.

In constructing curved timber steps:

- A line is drawn (using lime) on the ground to show the curve.
- Railway ties (15 cm x 20 cm) are used for the steps.
- Spacing varies according to the slope.
- Brackets for the steps are welded to a 90 cm section of rebar having a stabilizing wedge.
- Stakes can be set into concrete to help preserve the correct horizontal and vertical alignment.
- Plantings may be used to soften the edge of the steps.

Refer to the slope diagram in this section to calculate the number of steps relative to the percent slope.

Figure 51: Curved timber steps

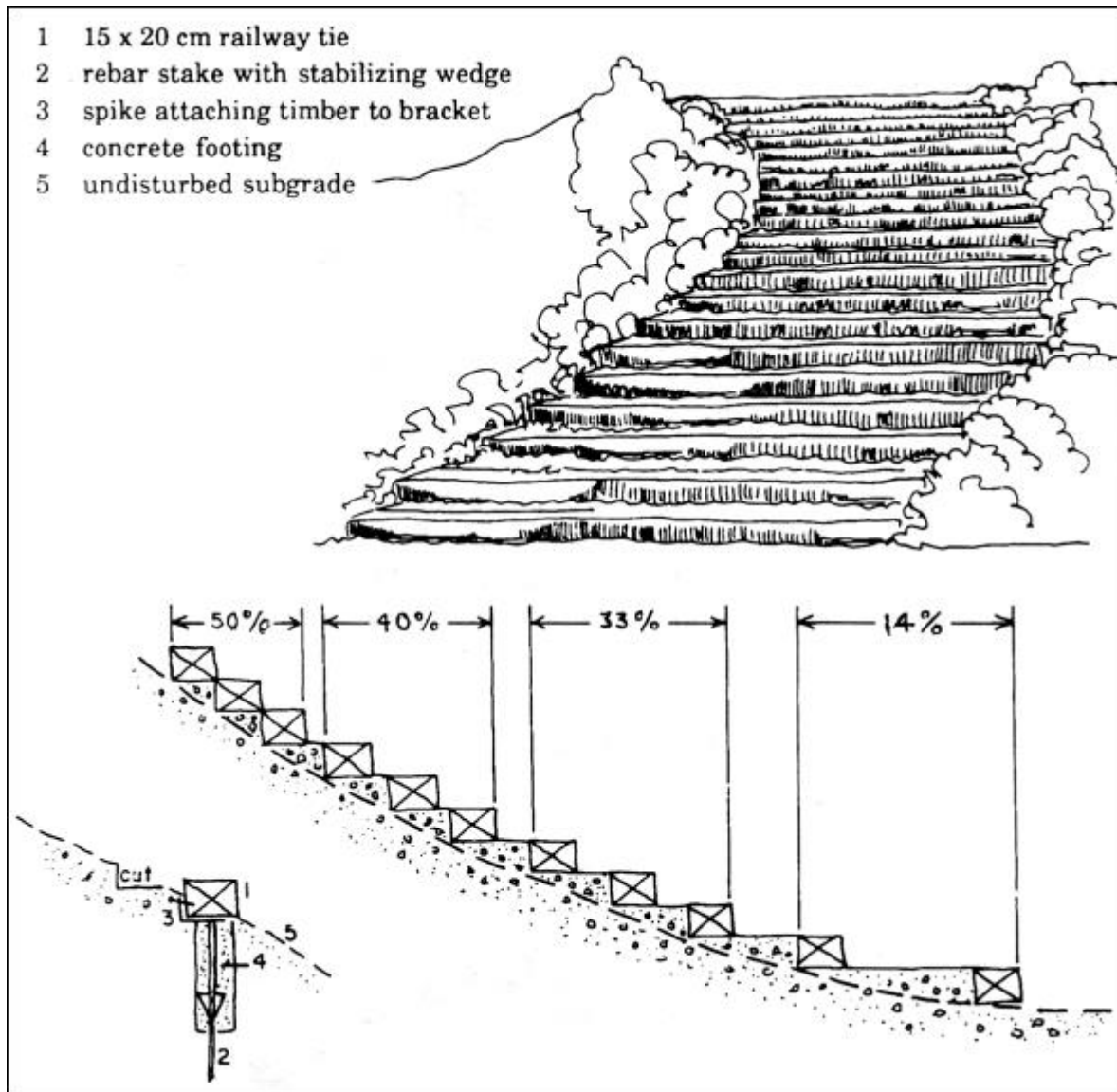

Ramped Steps

Ramped steps are used where it is necessary to level out gentle slopes. Timber or log risers may be used. On timbers, brackets welded to steel stakes may be preferable to a stake-only anchor.

Figure 52: Ramped steps

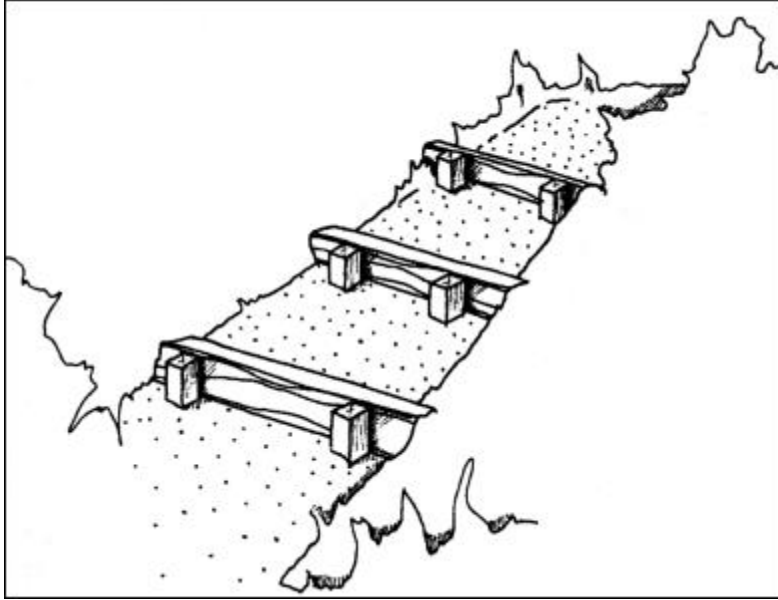

Plank steps on stringers

Steps on stringers are used in high-use areas or where rocky materials or surface roots make it difficult to set steps into the ground.

Figure 53: Plank steps

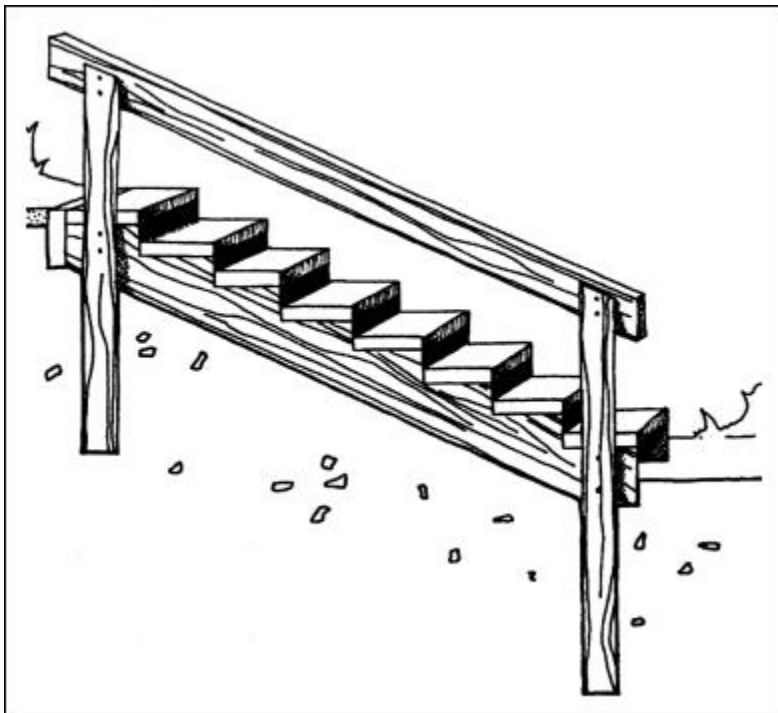

Ladders

Ladders may be used on back country trails for more agile hikers where grades exceed a 1:1 slope. They are readily constructed from on-site materials, and may be used for short, steep ascents or directly on the ground on less steep slopes, with the rungs acting as steps.

Crib Ladder

This technique is useful where a very steep slope, or one with rock or roots near the surface, makes it difficult to secure regular steps.

It consists of a log ladder laid into or up against the slope. Each step is backfilled with gravel or rock scree. There should be no space behind the rungs for people to step into. Tops of the rungs should be flattened with an axe. There are many possible variations of this technique, using 300 mm (12 in.) spikes to fasten the logs together.

Figure 54: Crib ladder

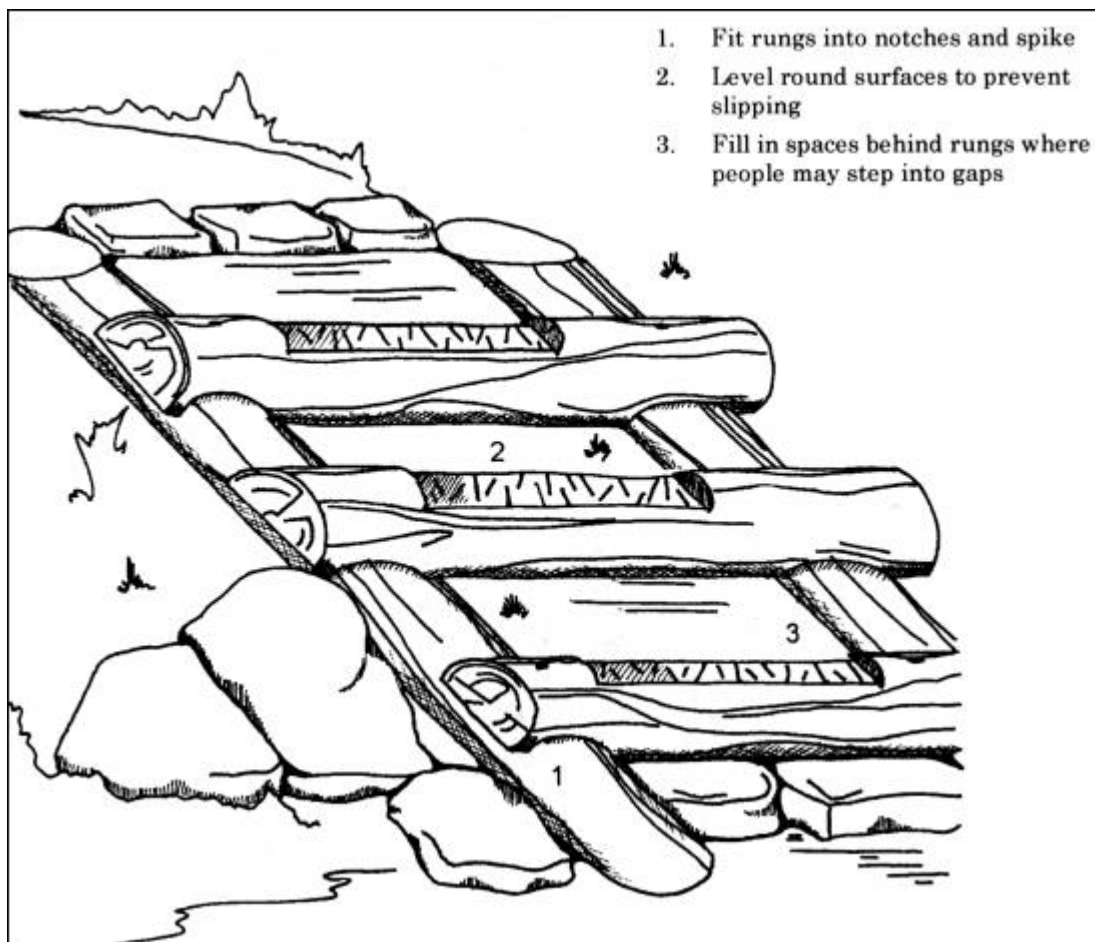

Stiles

Stiles can be used to provide hikers with a means of crossing public lands that have been fenced, without having to install gates (preferred by ranchers). In some cases, they may also be used as a

method of controlling access and for allowing pedestrians only (e.g., to prevent motorized or bicycle access).

Figure 55: Stiles

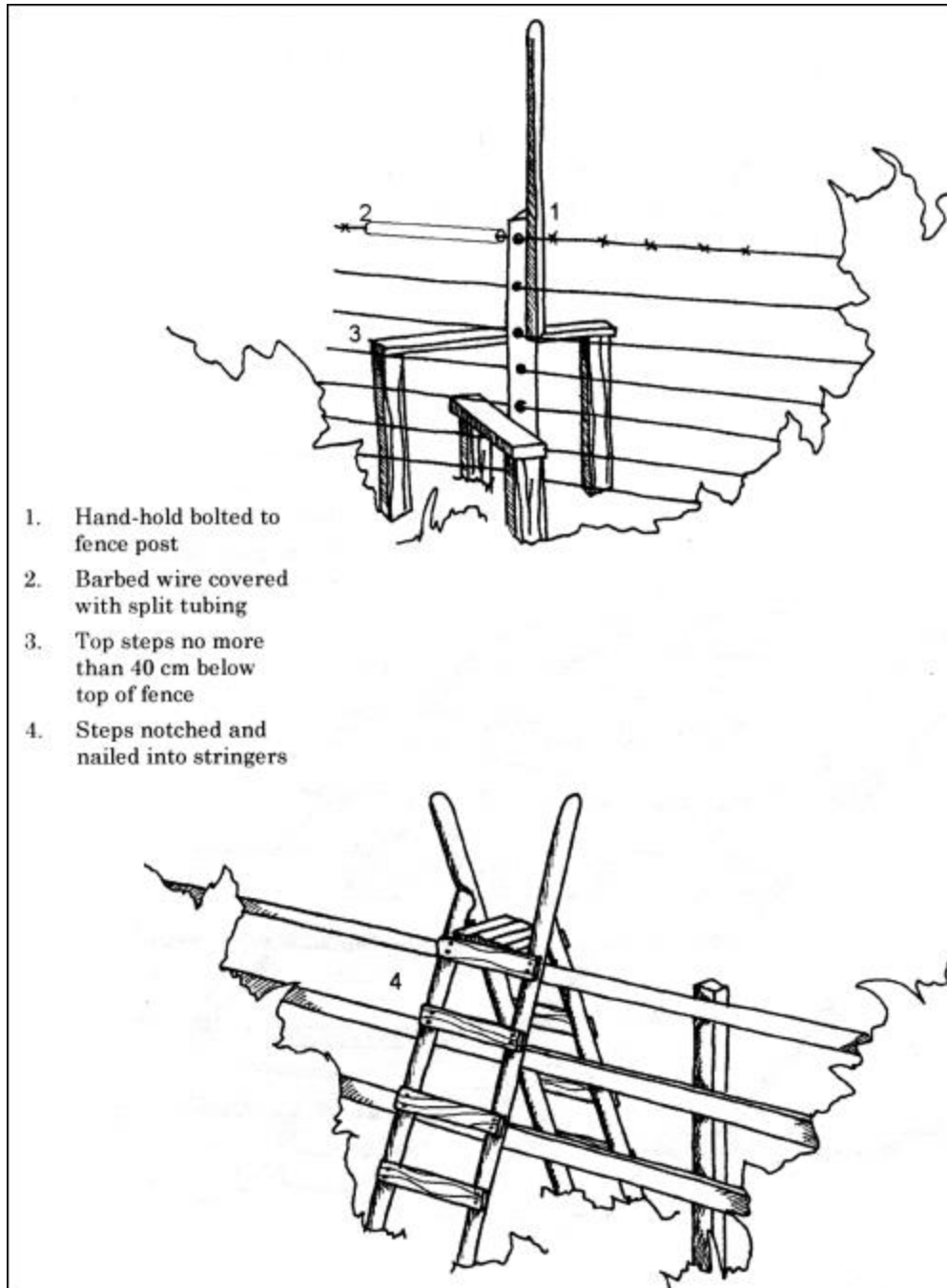

[[Top](#)]

10.5 Trail Monitoring And Maintenance Program

A monitoring and maintenance program helps ensure the safety of the trail user and the preservation of the trail environment.

Trail maintenance responsibilities begin as soon as a trail is completed and open for public use.

Trail monitoring and maintenance should reflect the level of use and the classification of each trail.

Objectives

Trail maintenance is carried out to:

- provide user safety;
- protect the environment;
- provide user access and convenience; and
- protect investments.

Trail Maintenance Priorities

1. Safety considerations should always be the first priority. Unsafe conditions should be corrected or normal use restricted.
2. Environmental and trail damage should be corrected and actions taken to prevent further damage.
3. User convenience should be considered.

[[Top](#)]

10.5.1 Trail Condition Log

The basis for a well-managed monitoring and maintenance program is an inventory of trails and related facilities, or a trail log developed during condition surveys and inspections. A trail log, or initial inventory, identifies and documents the physical conditions of a trail, including all structures.

The log should provide sufficient detail to allow for appropriate maintenance decisions. Information should be:

- recorded by location;
- based on accurate measurement of the trail or from the original Construction Log; and
- marked on a detailed trail map.

The trail log, or inventory, should provide information about physical characteristics and features, including:

- | | |
|-----------------------------------------------|----------------------------------------------------------|
| <input type="checkbox"/> trail classification | <input type="checkbox"/> length |
| <input type="checkbox"/> grade | <input type="checkbox"/> boardwalks |
| <input type="checkbox"/> tread width | <input type="checkbox"/> water bars/drainage
measures |
| <input type="checkbox"/> surfacing | <input type="checkbox"/> bridges |
| <input type="checkbox"/> switchbacks | <input type="checkbox"/> culverts |
| <input type="checkbox"/> stairs | <input type="checkbox"/> signs |
| <input type="checkbox"/> stream fords | <input type="checkbox"/> campgrounds or huts |
-
- safety concerns (cliffs, canyons, trails crossing tidal zones)
 - significant features (bogs, caves, archaeological sites, wildlife trees)
 - seasonal conditions (flooding during spring months or heavy rains, subject to late spring avalanches)

[[Top](#)]

10.5.2 Maintenance Levels

The maintenance level assigned to a trail will depend on a number of factors, including:

- classification of the trail (Type I- IV);
- management objectives;
- volume and type of users;
- environmental impact;
- trail deterioration;
- purpose of the trail;
- existing trail standards;
- trail investment; and
- availability of funds.

In general, high-use and high-standard trails will receive a higher level of maintenance. This also implies a quicker response to trail deterioration.

In general, the following rules-of-thumb should be considered for summer and winter maintenance of trails.

Heavy use summer trails should be:

- repaired in the spring before the beginning of the heavy use season; and
- maintained at least once a month during the season.

Winter ski trails should be:

- maintained after significant snowfalls, or as trail conditions deteriorate due to usage and environmental factors.

[[Top](#)]

10.5.3 Trail Monitoring

Condition Survey

A condition survey identifies and documents the physical condition of a trail and lists the deficiencies that require maintenance efforts. Often the initial condition survey is completed at the same time as the trail inventory.

A standardized checklist, such as the one on the following page, should be compiled to give a clear and concise record of trail conditions and required maintenance procedures. Specific maintenance requirements should also be indicated on a trail map of sufficient scale (1:50 000 minimum).

The person responsible for the trail condition survey must be knowledgeable about the entire maintenance process. Any damage or deterioration that will require further work should be noted. This information, coupled with facility standards, yields manpower, equipment, material costs and work scheduling.

For lower use trails, the yearly condition survey could be undertaken at the same time the first trail crews clear out windfalls at the beginning of the season.

A Forest Service inspection form is available for recreation trails (FS 1047) to assist staff and contractors in inspection and monitoring.

Information on Trail Conditions and Safety

It is important that information about trail conditions be made available to users as soon as possible. This is particularly important during the early part of the season in the case of summer trails, since users will want to know when the high alpine passes are free of snow, or whether bridges have been washed out.

Such information is invaluable to users who are choosing potential routes, and may well reduce the risk of injury to the public.

Trail Maintenance Checklist

Note: Locations should be indicated on the trail map

HAZARDS

Potential safety hazards should be addressed immediately. If a situation is unsafe, a notice should be posted or the trail closed until the hazard has been repaired. The public should be informed accordingly at the trail head and appropriate information offices.

- River/creek crossings
- Slides/washouts
- Hazard trees

VEGETATION MAINTENANCE

- Windfall removal
- Brush clearing, including removal of hazardous branches
- Hazard tree removal
- Slope revegetation
- Viewpoint maintenance
- Close off unwanted trails and shortcuts, and restore vegetation

DRAINAGE MAINTENANCE

Cleaning and repairing structures:

- | | |
|-------------------------------------------|---------------------------------------|
| <input type="checkbox"/> Culverts | <input type="checkbox"/> Cross drains |
| <input type="checkbox"/> Waterbars | <input type="checkbox"/> Grade dips |
| <input type="checkbox"/> Drainage ditches | |

STRUCTURE MAINTENANCE

- | | |
|-------------------------------------------------|-----------------------------------------------------------|
| <input type="checkbox"/> Bridge repair | <input type="checkbox"/> Cribbing & retaining wall repair |
| <input type="checkbox"/> Steps and stair repair | <input type="checkbox"/> Barrier and handrail repair |
| <input type="checkbox"/> Boardwalk repair | <input type="checkbox"/> Deck board replacement |
| <input type="checkbox"/> Shelter repair | |

TREAD MAINTENANCE

- Draining/hardening of mud holes and boggy areas
- Washout repair
- Slump repair
- Grubbing rocks, roots, stumps
- Turnpike section repair
- Surface repair and removal of loose rocks

- Surface replenishment (similar or minimal maintenance material)

INSTALLING ADDITIONAL DRAINAGE STRUCTURES

- | | |
|-------------------------------------------|---------------------------------------|
| <input type="checkbox"/> Waterbars | <input type="checkbox"/> Cross drains |
| <input type="checkbox"/> Culverts | <input type="checkbox"/> Grade dips |
| <input type="checkbox"/> Drainage ditches | |

SIGN MAINTENANCE

- | | |
|----------------------------------------------------------------|-------------------------------------------------------------|
| <input type="checkbox"/> Sign repair | <input type="checkbox"/> Sign replacement |
| <input type="checkbox"/> Cairn repair | <input type="checkbox"/> Barricade or closure device repair |
| <input type="checkbox"/> Trail marker replacement or additions | |

Condition Indicators

It is easy for a trail maintenance program to become strictly reactive to immediate problems. Long-term indicators are therefore useful for capturing trends in trail deterioration.

For example:

- trail braiding in wet alpine areas can easily lead to multiple trails across an area; and
- depth of a trail tread can increase unnoticed over several years until spring runoff channelling into the trail causes washouts or soil slumps.

These types of problems harm the environment and are also expensive to repair.

A good program monitors long-term indicators along each trail, using notes and/or photos over time. Indicators can include:

- depth of trail tread;
- trail width;
- area of soil compaction;
- development of side trails; and
- number of muddy sections per kilometre.

This should be done in conjunction with the Limits of Acceptable Change (LAC) process, wherever LAC is part of the management approach.

Unauthorized trail construction or maintenance

Section 102, Forest Practices Code

The Forest Practices Code requires that individuals or groups planning to construct, rehabilitate or maintain a trail or recreation facility must prepare a proposal and submit it to the district manager of the appropriate forest district. District manager consent is required before any work

can begin. (For more information refer to Section 102 of the Forest Practices Code and the *Trails and Recreation Facilities Guidebook*, 1995, Ministry of Forests & BC Environment.)

Risk Management

Inspection and maintenance

Routine trail and recreation facility inspection and maintenance is critical to both establishing a reasonable standard of care and in fulfilling government's mandate to maintain safe, sanitary, socially acceptable and environmentally sound conditions. A risk management program with an assessment process, including well-maintained records for inspections and follow-up repairs, is critical to proving, in the case of litigation, that a standard of care existed and was adhered to.

Safety hazards must be dealt with immediately - either through repair or through closure of the trail.

Signs

When it comes to cautionary signs, a balance must be struck between the safety of the users and the naturalness of the site. Generally, any known hazard on actively managed trails, which could result in personal injury, should be signed. Wording and images for any sign must be approved by the trail manager to ensure information is accurate and consistent. In some cases, legal advice may be required.

The question of what is "reasonable" changes with the dominant user. On trails that are easily accessible to an urban population, trail managers may need to caution visitors against hazards that are more obvious than those on remote trails visited mainly by experienced back country users.

Trail Closures

In some instances, where there is a high risk of incidents on a trail, managers may choose to close the trail. Whether permanent or temporary, notices must clearly set out the nature of the closure. This may well reduce the risk of injury to the public.

When closure is in effect, the land is considered unmanaged for recreation use and the trail manager is not perceived as having "invited" the public to a risky spot. Consequently, liability is reduced.

Section 105 of Forest Practices Code may be used to issue written orders to close or restrict use of an area or a trail (see Appendix *Section 105 Recreation Orders*).

[[Top](#)]

10.5.4 Summer Use Trail Maintenance

Required Maintenance Activities BEFORE Heavy Use Season

The following maintenance activities are normally required on trails before the heavy summer use season begins.

Clear windfalls, dangerous trees, and slides

These clearing repairs are made for user safety reasons and to prevent detouring off developed trails.

- Any slide debris or slumping of mud or soil onto the trail forces users to the outside edge, which is often on fill and the weakest part of the trail. Once the slide debris is removed, repair the trail tread to the original specifications.
- If a tree has fallen over a trail and cannot be easily removed, cut a gap to allow passage. In the case of wilderness or primitive routes, consider leaving the tree if it does not represent a major impediment, but chop a step into it if necessary.

Drainage repair

No factor in trail maintenance is more important than PROPER DRAINAGE.

Maintenance inspections should look for **existing and potential** drainage problems. Often minor, temporary works done early in the season can prevent major washouts from occurring later. Permanent follow-up work should be done as soon as possible. Potential problem areas should either be treated, or monitored to gauge the rate of trail deterioration.

- **Repair erosion-damaged elements promptly to prevent further damage.** Check for effects of erosion after spring run-off.
- Repair any wash-outs.
- Check and repair waterbars, ditches, culverts and dips, and construct additional drainage features if needed.

Remove new plant growth

- Trail brushing should be done annually, and is best done in the spring and early summer when new growth is soft.
- Selectively clear new or existing vegetation for viewpoints or vistas where appropriate - if this is not done for significant vista areas, spur trails will develop as users seek out the views.

Level or restore the trail tread

Remove loose rocks and debris from the tread surface.

- This is done, as necessary, to restore the tread to its original grades and slopes for safety and effective drainage.
- Use local materials to fill ruts, low spots or holes. Imported materials may be needed to correct soggy or muddy sections. Re-surface and fill approaches at the ends of bridges, boardwalks or corduroy sections.

Check and repair all structures

This work should be performed after spring runoff and after severe storms during the summer season.

- Check for signs of rot and decay, and remove debris from around bridge supports. Secure loose side rails or curb logs and re-spike all loose decking. Ensure any structural repairs and replacements meet the original construction requirements.
- Remove loose rocks from stream fords to help ensure a safe crossing.

Check, repair, or replace signs and markers

Again, this should be done prior to the heavy-use season.

- Remove any vegetation that obscures signs.
- Provide additional signs or trail markers where there is any confusion about trail route.
- Paint sign posts, rails, etc. as required.

Check parking lot

- Re-grade the trail head parking lot, if necessary.

Required Maintenance Activities DURING Heavy Use Season

These may be weekly or monthly tasks, as use and conditions warrant.

Maintain trailhead structures

This includes servicing such items as toilets and waste containers.

Restock information supplies - where trailhead kiosks are stocked with route or safety brochures, these should be restocked as required.

Remove windfall or other debris on the trail.

Other conditions - correct other hazardous conditions or problems as the need arises.

Drainage repair

Once again, no factor in trail maintenance is more important than PROPER DRAINAGE.

- Monitor and repair any erosion damage promptly to prevent further damage. Potential problem areas should either be treated, or monitored to gauge the rate of trail deterioration.
- Permanent follow-up work should be done on any temporary repairs as soon as possible.
- Check and repair waterbars, ditches, culverts and dips, and construct additional drainage features if needed.

Labour and equipment needs for maintenance

The most commonly required tools for trail maintenance (two-person crews) include:

- pointed shovel;
- double-bit axe;
- bow saw (and/or chain saw);
- brush axe;
- pruning shears;
- trenching tool;
- pruning saw;
- hammer; and
- brush mower

[[Top](#)]

10.5.5 Cross-country Ski Trail Maintenance

Pre-season maintenance is best carried out prior to the first snow. Clearing should remove twigs and branches at ground level so that protruding material will not injure falling skiers. Mowed trails tend to hold more snow than unmowed trails.

Ski season maintenance focuses on the snow cover. For more detailed information on snow packing, track setting and snow grooming procedures consult the *Cross-country Ski Trail and Facility Development: Construction and Maintenance Manual* prepared by Cross-Country B.C., Canadian Ski Association.

Trails located in woods or at the base of slopes will require minimum grooming, whereas trails in open, windswept areas become icy and will require frequent grooming. The main requirement of any well laid out trail will be the setting of new tracks after a heavy snowfall. Light snowfalls will not obliterate the old track. The simplest way to reset a trail is to ski it. A good track should provide a smooth level base that is sound and continuous, and is 2 to 5 cm deep.

For intensely used areas, a track vehicle may be required to compact new snow and set tracks. Compaction helps to extend the use season since compacted snow is slower to melt in the spring thaw. If tracks become badly iced from frozen rain or freeze-thaw cycles, a track cutter may be used to help improve them. A lighted track for night use may be considered for intensely used trails in rural settings.

Where tracksetting is required because of the level or kind of use, the ministry will cooperate with other agencies, public groups and the private sector to ensure that tracksetting services are provided, at no fee, on a cost recovery basis.

In addition, it may be appropriate for user fees to be charged for those trails where tracks are set. Such fees will be established through cooperative agreements with other agencies or through management agreements with private groups set on a cost-recovery basis, and collected by the agency that sets the tracks.

A major maintenance concern on ski trails is prohibiting ATV and snowmobile use. ATVs and snowmobiles obliterate ski tracks, create "moguls" that are difficult to ski across, roughen the trail surface, and cause trails to become overly compacted and icy, which are hazardous to users. Walkers and snowshoe users to a much less degree also break up parallel ski grooves. If walkers or snowshoe users are expected on ski trails, signs should remind them to stay to the side of the ski tracks.

[[Top](#)]

10.5.6 Trail Rehabilitation

Rehabilitation may be necessary when trails have been neglected for several seasons, or when trail development objectives change due to changes in ROS settings, management objectives or user requirements.

In determining the requirements of the proposed trail rehabilitation, it will be necessary to:

- define the development objectives;
- review the design process beginning at the concept planning stage, and establish the needs of the rehabilitation project; and
- evaluate trail location, length, layout, tread conditions, grades, alignments and structures to establish where alterations are required.

The time and cost requirements of a rehabilitation project will vary depending on the degree of deterioration or the degree of change in the trail management objectives.

[[Top](#)]

10.5.7 Cooperative Projects

Cooperative trail development and maintenance

Cooperative trail development and maintenance projects can benefit the public and the Forest Service not only in the short term (i.e., development cost savings), but also in the long term. Cooperative projects provide user groups with opportunities to become directly involved and see integrated and multiple resource use in action. Such projects can also provide a group with a sense of stewardship for an area.

Although cooperative projects can take considerable time and effort to initiate, they often result in less damage to the trail and associated structures, and greater public understanding of the Forest Service mandate.

Trail signage should acknowledge the cooperation of a group, but should not dominate the trail or potentially alienate other users.

Cooperative groups should be registered societies so that many members can contribute and have sustained long-term input.

An agreement between the Forest Service and a user group should:

- be clearly set out in writing;
- include what is expected of both parties; and
- include any conditions that would nullify the agreement.

[[Top](#)]

10.6 References

Cited References

A code of ethics for the enjoyment of outdoor British Columbia, (brochure), Outdoor Recreation Council of BC.

Cross-Country Ski Trail and Facility Development: Construction and Maintenance Manual. Cross-Country B.C., Canadian Ski Association. 1987.

Developing Your Wildlife-Viewing Site, Maps Alberta, Province of Alberta.

Forest Act, Province of B.C.

Forest Practices Code of British Columbia Act and Regulations, Province of B.C.

Manual for Trail Construction and Maintenance, Altman, R., H. Habgood and J. Braa, 1986, Federation of Mountain Clubs of British Columbia.

Offence Act, Province of B.C.

Parks Canada Trail Manual, Minister of Supply and Services, Heritage Canada.

Resource Planning Manual, Ministry of Forests

Standard Specifications for Construction of Trails, US Forest Service, 1984. Washington, D.C.

Trails Management Handbook, US Forest Service. 1987. Washington, D.C.

Trails and Recreation Facilities Guidebook, 1995, Ministry of Forests & BC Environment

Supplementary References

Black, J. and V. Hignett. 1982. *Outdoor Recreation Classification for British Columbia*, APD Technical Paper 8, Assessment and Planning Division, Ministry of Environment, Province of B.C.

Cole, B.L. 1977. *Field Guide for Routine Recreation Trail Maintenance*, Department of Natural Resources, State of Washington

Knopp, T. and J. Maloney. 1973. *Ski Touring Trail Planner*, North Star Planner, North Star Ski Touring Club of Minnesota and the U.S. Ski Association - Central Division.

[Contents](#) | [Previous](#) | [Next](#) | [Top](#)
[Recreation home page](#) | [Forests Practices Branch](#)

Last revised: 01/2001